

Aegis^{Plus} Ring Main Unit up to 24kV



Aegis^{Plus} builds upon the strong foundations of Aegis, to offer the following additional features and benefits:

- + Extensible and non-extensible range
- + Automation ready with integrated RTU
- + Network condition monitoring
- + Automatic Transfer Scheme (ATS)
- + Circuit breaker with auto reclose mechanism
- + Transformer protection with vacuum circuit breaker or HV fuse switch
- + Wide range of protection relays and Time Limit Fuse (TLF) devices
- + Indoor and outdoor installation
- + Enhanced internal arc safety
- + Multiple cable termination heights
- + Reduced spatial footprint
- + New options and accessories

To find out more about us, visit:
www.lucyelectric.com

Contents

Introduction to Lucy Electric	4	Direct cable connection (R)	20
Product panorama: MV and HV range	5	Standard features	
Introduction to Aegis^{Plus}	6	Optional features	
Installation and operating conditions – indoor/outdoor	7	Busbar earthing (Be)	21
Safety features	8	Standard features	
Applications	9	Optional features	
Aegis range presentation	10	Circuit breaker protection	22
a. Functions available		Time Limit Fuse (TLF)	
b. Non-extensible range		Circuit breaker protection	
– RMU – up to 5 ways		Options and accessories	26
c. Extensible range		Earth fault and short-circuit indicators (EFI)	
– RMU – 1-, 2-, 3-, and 4-way units		Voltage presence indication system	
– Available configurations		Voltage detection system	
– Extensibility system		Secondary injection	
d. Extensibility system		Actuators (motors)	
– Side extensibility		Shunt trip coils	
– Top extensibility		Cable bushings and cable terminations	30
Product characteristics	13	Cable bushings	
Aegis presentation (fascia labelled)		Cable compartment	
User interface and interlocking mechanism		Cable terminations	
Load Break Switch: L	15	– Bolted separable	
Line diagrams		– Insulating bushing boot	
Standard features		– Heat shrink insulating bushing boot	
Optional features, factory fitted		Internal arc protection	35
Optional features also available as retrofit		Internal arc classification (IAC)	
HV fuse switch function: F	16	Methods of protection	
Line diagrams		Air metering unit	36
Standard features		Product characteristics	
Optional features, factory fitted		Available configurations	
Optional features also available as retrofit		CTs and VTs available	
Circuit Breaker; V, C and T modules	17	Smart-grid ready	38
Line diagrams		Gemini 3 RTU characteristics	
Standard features		Added functionality and benefits	
Additional options for C function		Automatic transfer scheme	
Optional features, factory fitted		Gemini Analogue Measurement Module (AMM)	
Optional features also available as retrofit		Gemini DC Analogue Input Module	
Busbar Sectionaliser SL switch	18	Technical data	42
Standard features		Aegis ^{Plus}	
Optional features		Metering unit	
Busbar Sectionaliser SV circuit breaker	19	Dimensions	45
Standard features		Aegis ^{Plus}	
Optional features		Metering unit	
		Order form	47

Introduction to Lucy Electric

Lucy Electric is an international leader in switching, protection and automation solutions for electrical distribution networks. With more than 100 years of engineering heritage, the company specialises in secondary power distribution, delivering high-performance medium voltage switchgear, overhead line equipment, and advanced automation and retrofit solutions for utility, industrial and commercial customers worldwide.

Engineering excellence sits at the heart of Lucy Electric. By combining deep technical expertise with advanced technology, the company delivers reliable, high-quality solutions designed to meet the most demanding operational and environmental requirements.

A comprehensive product portfolio is supported by specialist services and dedicated after-sales support throughout the entire product lifecycle.

Continuous innovation is driven by a specialist research and development centre in the UK, while dedicated manufacturing facilities provide full control over production quality.

Lucy Electric's operations are truly global, with offices in Thailand, Africa, Brazil, Malaysia, Dubai, Saudi Arabia, South Africa and the UK. The company has manufacturing facilities in the UK, the UAE, Saudi Arabia, Thailand, Brazil and India. Together, with a network of industrial partners and contractors, the company's infrastructure supports projects in more than 50 countries worldwide.

Ring main unit range evolution

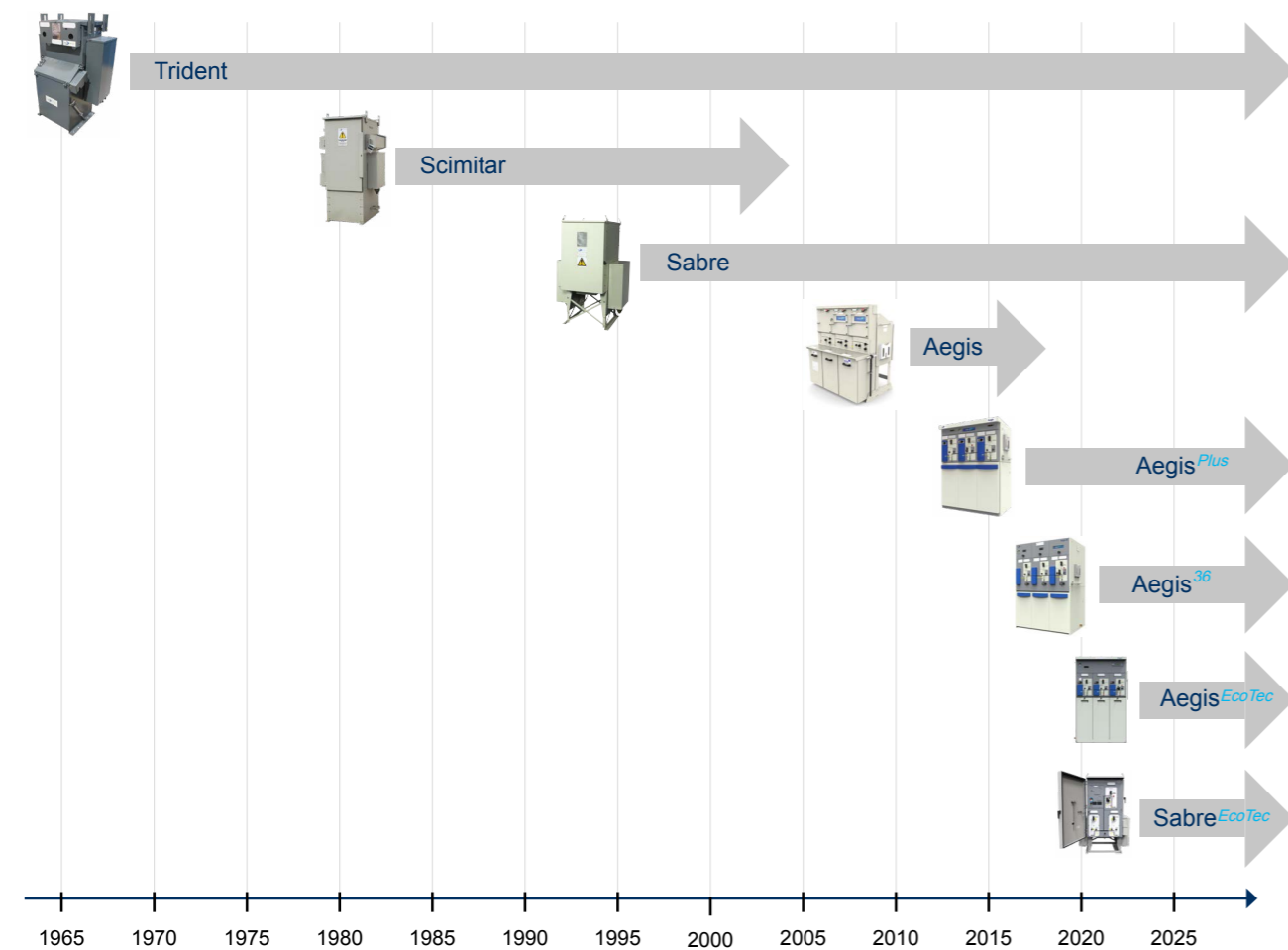

Product panorama: Lucy Electric medium voltage and high voltage range

Ring Main Units		Rated Voltage (up to)	Mode of Fault Current Interruption	Insulation Medium	Rated Current (up to)	Mounting	Installation Condition	Operation
	Aegis³⁶	38kV	Vacuum	SF6	630A	Ground/Transformer	Indoor/Outdoor	Local/Remote
	Aegis^{EcoTec}	12kV/24kV	Vacuum	Synthetic Air	630A	Ground	Indoor/Outdoor	Local/Remote
	Aegis^{Plus}	24kV	Vacuum/HV Fuse	SF6	630A	Ground/Transformer	Indoor/Outdoor	Local/Remote
	Sabre^{EcoTec}	12kV/17.5kV	Vacuum	Synthetic Air	630A	Ground/Transformer	Indoor/Outdoor	Local/Remote
	Sabre	24kV	Vacuum	SF6	630A	Ground/Transformer	Indoor/Outdoor	Local/Remote
	Trident	15.5kV	Fuse	Oil	630A	Ground/Transformer	Indoor/Outdoor	Local/Remote
Metering Unit								
	Aegis^{Plus} / Aegis³⁶	24kV / 38kV		Air	630A	Ground/Transformer	Indoor/Outdoor	
	Sabre	15.5kV		Air	630A	Ground/Transformer	Indoor/Outdoor	
	Oil	15.5kV		Oil	630A	Ground/Transformer	Indoor/Outdoor	

Introduction to Aegis^{Plus}

Aegis^{Plus} builds on the proven foundations of Aegis, extending the RMU range with enhanced features and capabilities designed to meet the evolving technical and operational requirements of customers worldwide. Automation-ready units now incorporate integrated Remote Terminal Units (RTUs) in the form of our cutting-edge Gemini range, enabling instant smart grid functionality.

Structural tank welding is carried out using a robotic process, ensuring consistently high reliability and a product life expectancy of more than 30 years. The housing is fully treated using zinc coated steel and electrostatically applied, oven cured paint, providing robust resistance to degradation from pollution and harsh climatic conditions.

Aegis^{Plus} is available in both extensible and non-extensible configurations, with a wide range of functional options housed within a single, sealed tank. The range has been engineered for the most demanding environments, including the option to convert units from indoor to outdoor installation, extending ingress protection to IP54. These advances have been achieved alongside a reduction in spatial footprint, resulting in a compact design that is straightforward to install. A range of advanced air metering units is also available, developed from the ground up with Aegis^{Plus} in mind to offer full metering capability.



Aegis^{Plus} with LLV configuration

Characteristics:

- 12kV, 17.5kV and 24kV ratings
- Extensible and non-extensible range with up to 5 switching functions in a single tank
- Hermetically sealed stainless steel tank insensitive to environment
- Intuitive single line mimic diagram for simple and safe operation
- Vacuum circuit breaker for more effective and cleaner interruption
- Provision for motor actuators for remote operation and control
- Integrated cable testing facility on front face, eliminating the need for cable disconnection
- Suitable for indoor and outdoor applications
- Extensive range of Relays, TLF, VDS and EFI devices
- Low roof height designed for kiosks and mini substations
- Easy integration with SCADA and BMS networks

Standards

Aegis^{Plus} complies with the latest international standards:

- | | |
|-----------------|---|
| IEC 62271 – 100 | Alternating current circuit breakers |
| IEC 62271 – 102 | Alternating current disconnectors and earthing switches |
| IEC 62271 – 103 | Switches for rated voltages between 1kV and 52kV |
| IEC 62271 – 105 | Alternating current switch fuse combinations |
| IEC 62271 – 200 | AC metal enclosed switchgear and control gear |
| IEC 62271 – 206 | VPIS systems for rated voltages between 1kV and 52kV |
| IEC 62271 – 1 | HV switchgear and control gear: common specifications |
| IEC 61243 – 5 | Voltage detecting systems (VDS) |
| IEC 60255 | Measuring relays and protection equipment |

Installation and operating conditions

IP 54 - Outdoor



IP 41 - Indoor



- Indoor and outdoor type units
- Maximum altitude of operation without derating 1000m (above sea level) *
- Installation medium: SF6 Gas
- Rated pressure at +20°C: 0.04 mpa
- Interruption medium: vacuum and fuse

* For higher altitude applications, please contact your local Lucy Electric sales office

Safety features

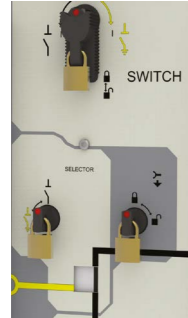

Operation mechanism

The mechanism consists of one operating shaft and one selector. The operating shaft is used for switching ON/OFF (Mains or Earth) and the selector is used for selection of the Mains or Earth positions. It is impossible to simultaneously close the Load Break Switch/Circuit Breaker and the Earth switch.

The mechanism incorporates mechanical interlocks and padlocking facilities to improve operational safety and security.

Anti-reflex mechanism

Ensures a time delay between switching operations to allow sufficient time for the main (primary or upstream) breaker to trip and clear a fault.



Internal Arc withstand

The SF6 gas insulated, stainless steel tanks are fully internal arc rated and this feature is also available on the cable compartments (optional) to ensure maximum operator safety in the event of internal faults. As standard, Aegis^{Plus} units are rated for AF (operator safety from the front of the unit) and there is an option to request AFL (front and side) and AFLR (front, side and rear protection).

For more details, please refer to the internal arc protection page 35.

Gas pressure indicator

- A gas pressure indicator is fitted to the tank which has green and red sectors to indicate the minimum permissible pressure for safe operation
- An optional remote gas pressure alarm 1NO can be specified to alert the operator in the event of gas pressure falling below the permissible operable limit
- Temperature compensated gauge available as an option.

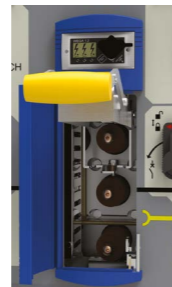

Earth and test facility

The cable earth and test facility is an optional feature on the Load Break Switch and the Circuit Breaker. It is located at the front of the unit for easy access. It is used for testing cable insulation and to locate faults in the circuit without the need to remove the main cables from the cable compartment, which improves the operator safety.

The cable test access cover is fully interlocked and cannot be opened until the Load Break Switch or Circuit Breaker Switch is in the Earth ON position. The test bushings are earthed with an earth star point which has to be removed for cable tests.



Cable compartment

The cable compartments are located at the front of the unit with horizontally mounted DIN 400 Type C bushings for ease of cable connection.

For enhanced operator safety, the cable compartments are earthed and fully interlocked, allowing operator access only if the function is in the Earth ON position. There is an option to select these cable compartments with Internal Arc ratings as per IEC standard.

Earth stud in cable compartment

A fully rated earth stud is fixed inside the cable compartment, located towards the bottom of the unit. It is used for connection to the main earthing system.

Applications

Aegis^{Plus} has been designed and developed for optimal performance in a range of applications, from diverse industrial requirements to power generation and distribution.

Energy

- Generation: wind power, solar power
- Distribution: compact substations, ring main sectionalising

Industries

- Water and wastewater, mining, minerals, automotive, iron and steel, cement and petroleum (oil and gas), food & beverage, paper

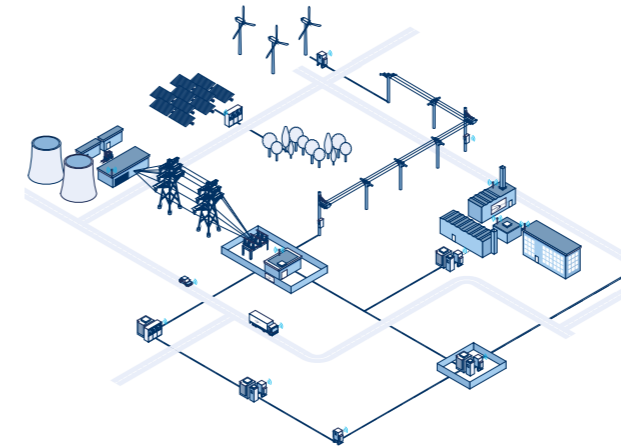

Infrastructure

- Tunnels, airports, seaports, metro station, underground railways

Buildings

- Commercial buildings: hospitals, shopping centres, hotels, office buildings, data centres, schools
- Residential buildings: houses, apartments



Aegis^{Plus} with busbar mounted VT for auxiliary power supply

Aegis^{Plus} range presentation

The Aegis^{Plus} range is available in Extensible and Non-Extensible formats, ranging from 1-function to 5-function configurations. An enhanced range of air metering units is also available, offering four metering applications.

Functions available:

Switching functions:

L: 630A Load break switch

Protection functions:

V: 630A Vacuum circuit breaker

T: 250A Vacuum circuit breaker

C: 630A Vacuum circuit breaker (Auto reclose mechanism)

F: 200A Fuse switch

Metering functions:

Mt: Tariff metering freestanding (Cable in / Cable out)

M1: Busbar metering (Busbar in / Busbar out)

M2: Cable in / Busbar out

M3: Busbar in / Cable out

Additional functions:

SL: 630A Busbar sectionaliser (switch)

SV: 630A Busbar sectionaliser (circuit breaker)

R: 630A Direct cable connection

Be: 630A Busbar earthing switch

For further details on metering, please refer to the air metering unit section on page 36.

Non-Extensible RMU range

This range has up to 5 functions insulated by SF6 gas in a single, hermetically sealed stainless steel tank. This solution is available in indoor (IP41) and outdoor (IP54) formats and is perfectly suited for integration into compact substations, to form standard ring main secondary networks with transformer protection.

Three voltage classes are available – 12kV, 17.5kV and 24kV.

Outdoor range (IP54)

The outdoor units are completely self-contained with no added spatial footprint. All configurations use the same enclosure, as shown on the right.

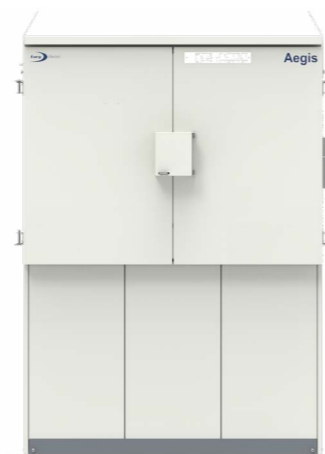

3-function outdoor unit

Indoor (Non extensible) unit, (IP41/ IP42)



3-function unit



4-function unit



5-function unit

Aegis^{Plus} range presentation

Extensible RMU range

The extensible range enables the addition of further functions to the left, right, or both sides of switchgear installed in secondary networks. This range has up to 4 functions insulated by SF6 gas in a single, hermetically sealed stainless steel tank. It is an ideal solution if additional functions are required at present, and provides freedom for further additions into the future.

Available in indoor and outdoor (IP41 and IP54) format, these units can be easily extended in any combination on-site, without specific tooling or floor preparation, and without the need to handle SF6 gas.

Three voltage classes are available – 12kV, 17.5kV and 24kV.



1-function unit



2-function unit



3-function unit



4-function unit

Product characteristics

General

Extensibility system

Side extensibility indoor applications - IP41 only

The coupling of additional functions is achieved via the extensible bushings located on the upper sides of Aegis^{Plus} (extensible model only).

Coupling bars as shown are inserted into the bushing slots to form a secure electrical connection. Units are then firmly bolted together via the fixing mounts to form a sturdy and lasting solution. The side extends on system is IP41 rated.

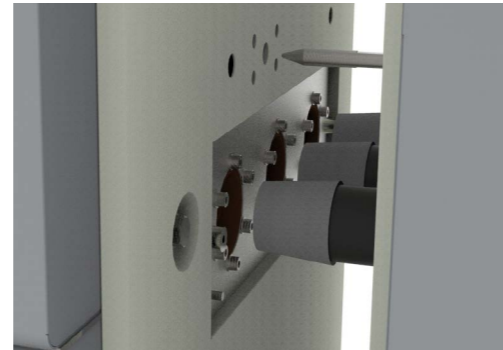

Top extensibility indoor and outdoor applications - IP41 and IP54

Top extensibility can also be achieved by DIN 400 Type C bushings located on the top of the unit. The busbar connection is earth-screened (non-screened available as option). Suitable for both indoor (IP41) and outdoor (IP54) installations.



Product presentation

1. Marshalling box
2. EFI: Earth Fault Indication + SCI: Short Circuit Indication
3. Gas pressure indicator
4. Protection relay
5. VDS: Voltage Detection System/ VPIS: Voltage Presence Indication System
6. Earth & Test cover
7. Load break switch operation
8. Load break switch selector
9. Load break switch earth and test and cable box interlock
10. Load break switch selector indicator
11. Load break switch indicator
12. Circuit breaker operation
13. Circuit breaker push-to-trip button
14. Circuit breaker disconnecter
15. Circuit breaker earth and test and cable box interlock
16. Circuit breaker disconnecter indicator
17. Circuit breaker indicator
18. Operating handle
19. Interlocked cable box cover

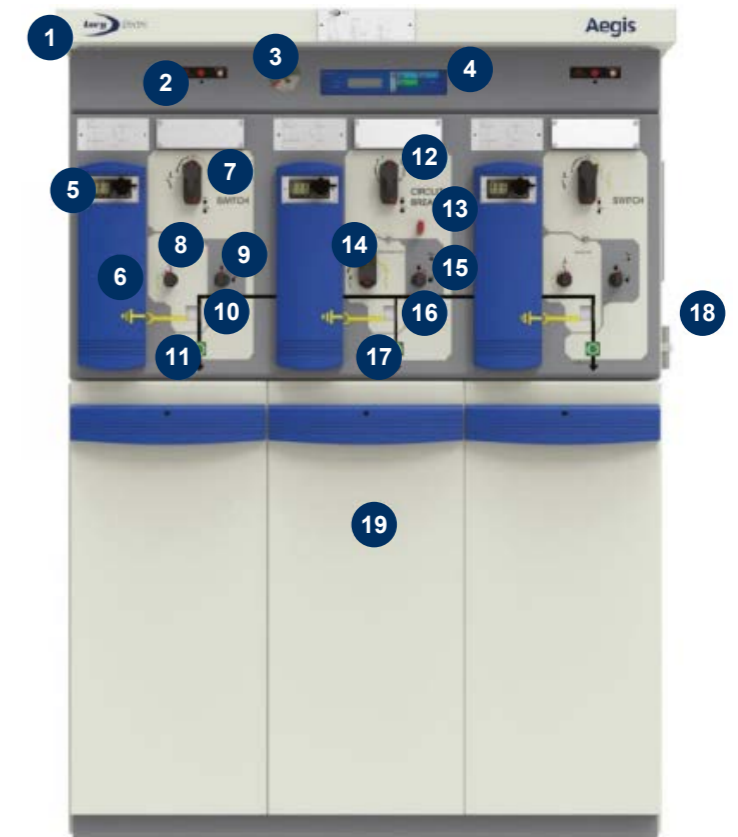

Product characteristics

L: 630A load break switch

User interface and interlocking mechanism

Safety interlocking

The Load Break Switch (LBS), Vacuum Circuit Breaker (VCB) and fuse switch modules have safety interlocked mechanisms via a manual, pull-down operation collar on the fascia. This collar inhibits the use of the operating handle when in the upper position, and when used in conjunction with padlocks, it prevents unauthorised access to the mechanisms. The LBS selector, VCB and fuse switch selector disconnecter have interlocked access via a rotary selector and operation collar respectively, which can be secured with padlocks to prevent unauthorised operation.

The cable boxes and Earth & Test facility also have safety interlocked access, via a single rotary selector located on the fascia. This too can be secured with padlocks to prevent unauthorised access to the cables and test bushings.

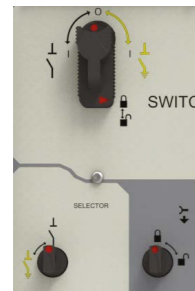

Load Break Switch

Position		Interlock status	
Load Break Switch	Selector	Cable Compartment Interlock	Earth and Test Interlock
ON	Main	Locked	Locked
OFF	Main	Locked	Locked
Earth OFF	Earth	Locked	Locked
Earth ON	Earth	Unlocked	Unlocked

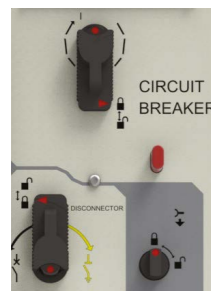

Circuit Breaker

Position		Interlock status	
Circuit Breaker	Selector	Cable Compartment Interlock	Earth and Test Interlock
ON	Main	Locked	Locked
OFF (Tripped)	Main	Locked	Locked
Earth ON	Earth	Unlocked	Unlocked
Earth OFF (Tripped)	Earth	Locked	Locked

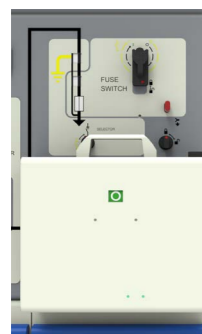

Fuse Switch

Position		Interlock status	
Fuse Switch	Selector	Cable Compartment Interlock	Fuse Holder Access Interlock
ON	Main	Locked	Locked
OFF (Tripped)	Main	Locked	Locked
Earth ON	Earth	Unlocked	Unlocked
Earth OFF (Tripped)	Earth	Locked	Locked

Standard features

- Three positions (ON, OFF & Earth), spring loaded mechanism, independent manual operation
- Single mechanism with two independent operating shafts, one for switch ON/OFF position and another for selecting Mains and Earth operation
- Interlocked selector, locked from operation when switch is in ON position
- Single line intuitive mimic diagram with clear indication to show the switch status (ON, OFF & Earth)
- Gas pressure indicator with Red and Green sectors to indicate minimum permissible pressure for safe operation (one per tank)
- Horizontal cable terminations at front of unit with DIN400 Type C bushings
- Fully interlocked cable compartment allowing entry only if function is in Earth ON position
- Padlock facility (8.5mm hole) for all operating positions

Optional features, factory fitted

- Internal arc rated cable compartment for additional safety
- Remote low gas pressure alarm 1NO
- Voltage presence indication system (VPIS)
- Voltage detection system (VDS)
- Operation counters
- Mechanical key interlocks with Castell keys
- Remote switch position indicator (1NO, 1NC, 2NO, 2NC)
- Fully interlocked cable Earth and Test (E&T) facility without needing to remove main cable connections
- Short circuit and Earth Fault Indicators (EFI)
- Wiring for motorisation

Optional features, available as retrofit

- Motor operation for Load Break Switch (only if unit is pre-wired for motorisation)
- Double cable terminations
- Surge arrester
- Wide range of cable clamps and glands to accommodate 1 and 3 core cables (refer to cable compartment section for further information)

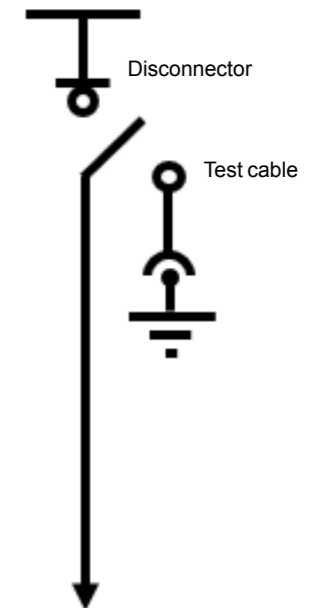

Product characteristics

F: 200A fuse switch

Standard features

- Three positions (ON, OFF, EARTH ON), spring loaded mechanism, independent manual operation
- Single mechanism with two independent operating shafts, one for switch ON/OFF position and another for selecting Mains and Earth operation
- Interlocked selector, locked from operation when switch is in ON position
- Single line intuitive mimic diagram with clear indication to show the switch status (ON, OFF, EARTH ON)
- Gas pressure indicator with Red and Green sectors to indicate minimum permissible pressure for safe operation (one per tank)
- Horizontal cable terminations at front of unit with DIN400 Type C bushings
- Fully interlocked cable compartment allowing entry only if function is in Earth ON position
- Padlock facility (8.5mm hole) for all operating positions

Optional features, factory fitted

- Internal arc rated cable compartment for additional safety
- Remote low gas pressure alarm (1NO)
- Voltage presence indication system (VPIS)
- Voltage detection system (VDS)
- Operation counters
- Mechanical key interlocks with Castell keys
- Remote switch position indicator (1NO/1NC and 2NO/NC)
- Fully interlocked cable Earth and Test (E&T) facility without needing to remove main cable connections
- Short circuit and Earth fault indicators (EFI)
- Wiring for motorisation

Optional features, available as retrofit

- Motor operation for Fused Switch (only if unit is pre-wired for motorisation)
- Double cable terminations
- Surge arrester
- Wide range of cable clamps and glands to accommodate 1 and 3 core cables (refer to cable compartment section for further information)

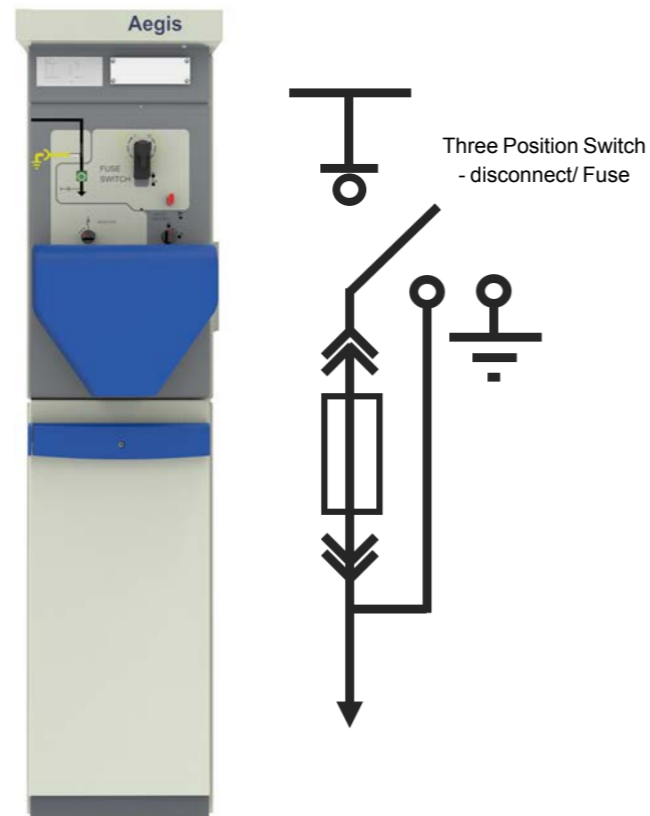

V, C and T: circuit breaker

Non-auto reclose mechanism
T module: 250A rated vacuum circuit breaker
V module: 630A rated vacuum circuit breaker
Auto reclose mechanism
C module: 630A rated vacuum circuit breaker

Standard features

- Three positions (ON, OFF, EARTH ON) achieved through the integral interlocking of a two position vacuum circuit breaker and two position off load isolator with independent manual operating mechanism
- Single mechanism with two independent operating shafts, one for circuit breaker ON/OFF position and another for selecting disconnect in Mains or Earth (isolation) in series the vacuum interrupter which carries out all load and fault making and breaking.
- Interlocked disconnect and selector, locked from operation when circuit breaker is in ON position
- Mechanical open and push-to-trip button for local operation
- Shunt trip coil for tripping circuit breaker under fault conditions
- Single line intuitive mimic diagram with clear indication to show the switch status (ON, OFF or Earth positions)
- Gas pressure indicator with Red and Green sectors to indicate minimum permissible pressure for safe operation (one per tank)
- Horizontal cable terminations at front of unit with DIN 400 Type C bushings
- Closing coil for remote operation (C function only)
- Protection CTs (current transformers) mounted on cable bushings / cables
- Fully interlocked cable compartment allowing entry only if function is in Earth ON position
- Padlock facility (8.5mm hole) for all operating positions

Additional options for C function

- Anti-pumping relay
- Additional shunt trip coil

Optional features, factory fitted

- Internal arc rated cable compartment for additional safety
- Remote low gas pressure alarm (1NO)
- Voltage presence indication system (VPIS)
- Voltage detection system (VDS)

- Operation counters
- Mechanical key interlocks Castell keys
- Remote circuit breaker position indicator (1NO/1NC and 2NO/2NC)
- Fully interlocked cable Earth and Test (E&T) facility without needing to remove main cable connections
- Self powered relay for protection (customer specific)
- Alternative time limit fuse protection (TLF)
- Wide range of Current transformers for protection
- Shunt trip coils for external tripping options
- Under voltage release coil cut
- Wiring for motorisation

Optional features, available as retrofit

- Motor operation for CB (only if unit is pre-wired for motorisation)
- Wide range of cable clamps and glands to accommodate 1 and 3 core cables (refer to cable compartment section for further information)

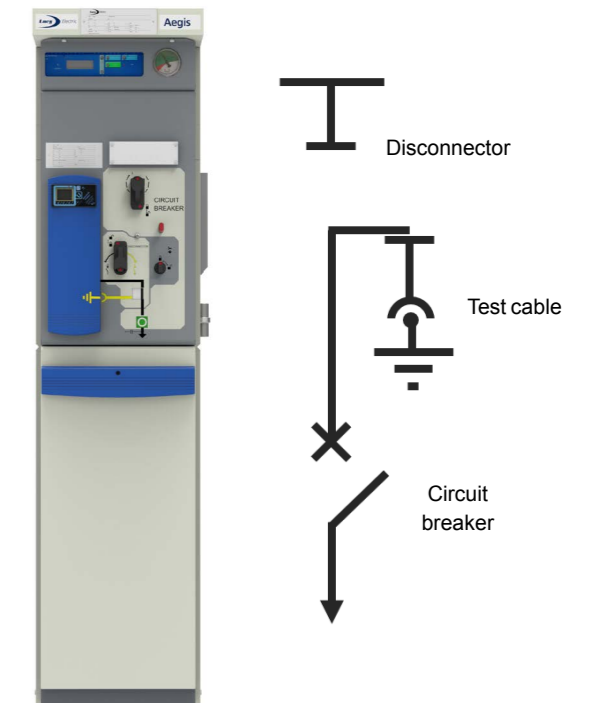

Product characteristics

SL: 630A busbar sectionaliser (switch)

Standard features

- Extensible bushings both sides
- Three positions (ON, OFF & EARTH ON), spring loaded mechanism, independent manual operation
- Single mechanism with two independent operating shafts, one for switch ON / OFF position and another for selecting Mains and Earth operation
- Interlocked selector, locked from operation when switch is in ON position
- Single line intuitive mimic diagram with clear indication to show the switch status (ON, OFF, EARTH ON)
- Gas pressure indicator with Red and Green sectors to indicate minimum permissible pressure for safe operation (one per tank)
- Padlock facility (8.5mm hole) for all operating positions

Optional features

- Motorisation
- Remote position indicator (1NO/1NC AND 2NO/2NC)
- Remote low gas pressure alarm 1NO
- Voltage presence indication system (VPIS)
- Voltage detection system (VDS)
- Operation counter
- Auxiliary contacts (disconnecter and earth switch position)
- Ronis key or Castell key interlock

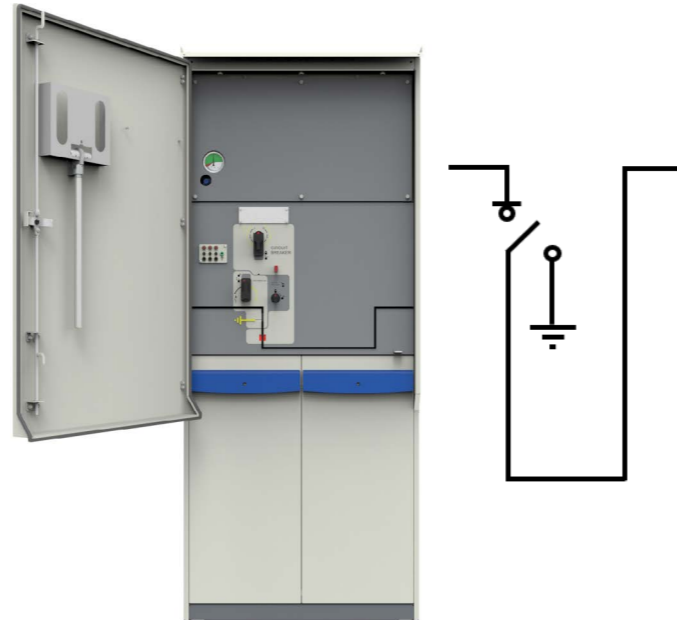

Product characteristics

SV: busbar sectionaliser (circuit breaker)

Standard features

- Three positions (ON, OFF, EARTH ON) achieved through the integral interlocking of a two position vacuum circuit breaker and two position off load isolator with independent manual operating mechanism
- Single mechanism with two independent operating shafts, one for circuit breaker ON / OFF position and another for selecting disconnecter in Mains or Earth (isolation)
- Interlocked disconnecter and selector, locked from operation when circuit breaker is in ON position
- Mechanical push-to-trip button for local operation
- Trip coil for receiving tripping signal from Protection relays
- Single line intuitive mimic diagram with clear indication to show the switch status (ON, OFF or Earth positions)
- Gas pressure indicator with Red and Green sectors to indicate minimum permissible pressure for safe operation (one per tank)
- Padlock facility (8.5mm hole) for all operating positions
- Extensible both sides

Optional features

- Remote low gas pressure alarm (1 NO)
- Voltage presence indication system (VPIS)
- Voltage detection system (VDS)
- Operation counters
- Mechanical key interlocks Castell keys
- Remote position indicator (1NO, 1NC and 2NO, 2NC)
- Self powered relay for short circuit protection (customer specific)
- Shunt trip coils for external tripping
- Motorisation
- Wide range of Current Transformers (CT's) mounted in the unit connected down stream (ex AMU or switch function)

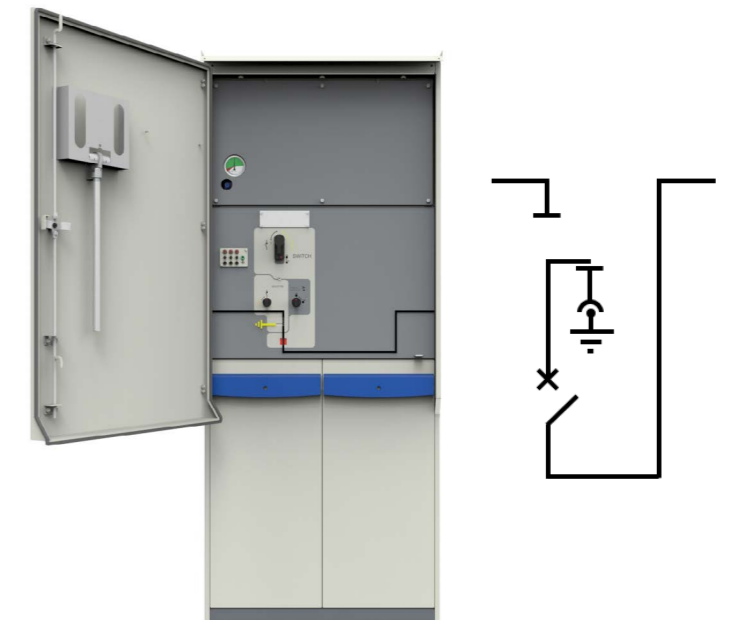

Product characteristics

R: 630A direct cable connection

Standard features

- Horizontal cable terminations at front of unit with DIN400 Type C bushings
- Left, right, or both sides extensible

Optional features

- Voltage presence indication system (VPIS)
- Voltage detection system (VDS)
- Short circuit and Earth fault indicators (EFI)
- Double cable terminations
- Surge arrester in cable compartment (only available with Single cable termination)
- Wide range of cable clamps and glands to accommodate 1 and 3 core cables (refer to cable compartment section for further information)

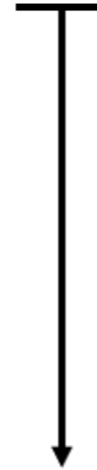

Product characteristics

Be: 630A busbar earth switch

Standard features

- Extensible bushings both sides
- Two positions (OFF & Earth ON), spring loaded mechanism, independent manual operation
- Single line intuitive mimic diagram with clear indication to show the switch status (OFF & Earth ON)
- Gas pressure indicator with Red and Green sectors to indicate minimum permissible pressure for safe operation (one per tank)
- Padlock facility (8.5mm hole) for all operating positions

Optional features

- Motorisation
- Remote position indicator (1NO/1NC and 2NO/2NC)
- Remote low gas pressure alarm (1NO)
- Voltage presence indication system (VPIS)
- Voltage detection system (VDS)
- Operation counter
- Auxiliary contacts (dis-connector and earth switch position)
- Castell key interlock on OFF and Earth ON position



Product characteristics

Circuit breaker protection – time limit fuse

Two types of protection devices are offered to protect the circuit breaker:

- Time Limit Fuse (TLF)
- Protection relays
- IDMT

TLF

When utilised in conjunction with circuit breaker type ring main units, time limit fuses (TLF) are a cost-effective method of providing fault protection for overcurrent and earth faults (optional) to a transformer of up to 2000kVA. The time limit fuse link is shunted with a trip coil which is fed from the protection current transformer. In the event of a fault, the fuse ruptures and the fault current is diverted through trip coil, which trips the circuit breaker.

It is a recognised method of protection and was developed to comply with EA 41-26 (now superseded by ENA TS 41-41) with fuse links in accordance with ENA TS 12-6.

It should be noted that the TLF protection system is not a device for limiting overload levels of individual transformers. It should be used for fault protection only.

The TLF system provides protection for overcurrent and earth faults between the MV circuit breaker and the LV protection device. The selected fuse rating should be such that it allows for discrimination between the MV & LV devices. This will ensure that the circuit breaker does not open for faults beyond the LV device.

A TLF equipped circuit breaker can be fitted with a shunt trip coil to enable tripping for the circuit breaker from other remote signals such as transformer Buchholz, winding temperature, or LV intertripping.

TLF protection is a cost-effective way of utilising the advantages of circuit breaker technology without the expense of IDMT relays at loads up to 2MVA and is used extensively throughout the world.



Fuse dimensions: Length 57mm x Diameter 13mm

Circuit breaker protection – time limit fuse

Recommended TLF settings

	Rated voltage (kV)	Transformer ratings (kVA)							
		200	315	500	800	1000	1250	1600	2000
CT ratio 50/5	3.3	10A							
	6.6	5A	10A	15A					
	11	3A	5A	10A	15A				
Earth fault setting = 25A (instantaneous trip)	13.8	3A	5A	10A	15A				
	24			3A	5A	7.5A			
CT ratio 100/5	3.3	5A	10A	15A					
	6.6		5A	7.5A	12.5A	15A			
	11			5A	7.5A	10A	12.5A	15A	
Earth fault setting = 30A (instantaneous trip)	13.8			5A	7.5A	10A	12.5A	15A	
	24						5A	5A	7.5A

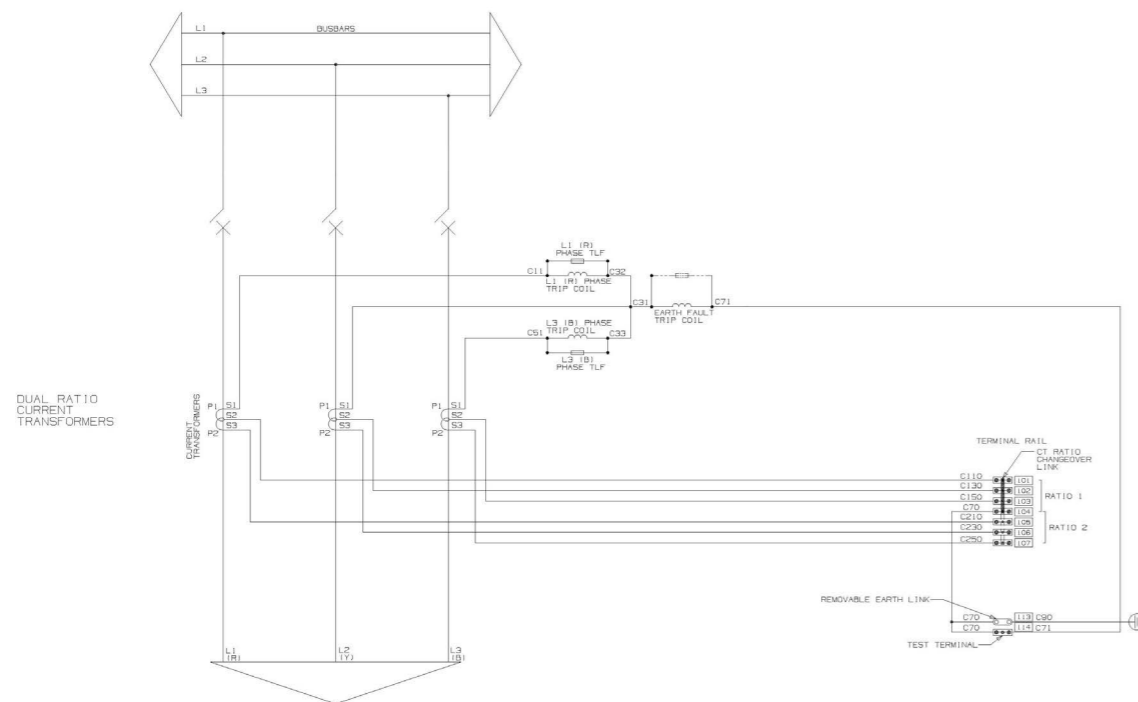

Product characteristics

Circuit breaker protection – relays

Protection relays

The Aegis^{Plus} range can be fitted with self powered relays for protecting the transformer or downstream network from fault currents by tripping the Circuit Breaker. These relays incorporate many advanced features and have a variety of settings to provide discrimination protection in networks.

The self powered feature eliminates reliance on external power sources to provide greater operational reliability. Optional password protection ensures that users have complete control of the device, and fault occurrences can be stored in non-volatile memory for greater assurance.



Features

- Short circuit and overcurrent protection
- Dual and self powered for greater operational assurance
- Earth fault and thermal overload protection
- Added tripping functionality including circuit breaker and remote tripping
- Tripping indication and fault recording
- Measurement of fault currents
- Multiple I/O for diverse applications
- Modbus protocol support
- Digital display and LED indication
- Password protection

Benefits

- Reduced fault time with detailed diagnostics
- Wide range of transformers supported
- Fast response protection of MV networks
- Support for diverse industrial applications
- Improves reliability of circuit breaker
- Simple operation with minimal maintenance

Aegis^{Plus} is fully compatible with the relays below:

	Woodward	Ashida	Fanox	
	WIP1	ADR241S	SIA-C	SIA-B
Power				
Self powered	✓	✓	✓	✓
Auxiliary powered	✓	✓	✓	✓
Dual powered	✓	✓	✓	✓
Protection				
Earth fault protection	✓	✓	✓	✓
Overcurrent protection	✓	✓	✓	✓
Short circuit protection	✓	✓	✓	✓
Thermal overload protection		✓		✓
Control				
Circuit breaker tripping	✓	✓	✓	✓
Remote tripping	✓	✓	✓	
Tripping indication	✓	✓	✓	✓
Fault recording	✓	✓	✓	✓
Measurements				
Earth fault current	✓	✓	✓	✓
Peak demand current			✓	
Phase current	✓	✓	✓	✓
Inputs / Outputs				
Phase current inputs	✓	✓	✓	✓
Earth fault current inputs	✓	✓	✓	
Logic inputs		✓	✓	
Logic relay outputs		✓	✓	
RS 485 communication port	✓	✓	✓	
Protocols				
Modbus	✓	✓	✓	✓
Characteristics				
Display	✓	✓	✓	✓
LED indicator	✓	✓	✓	✓
Fault memory	✓	✓	✓	✓
Setting via buttons	✓	✓	✓	✓
Password protection	✓	✓	✓	✓

Key ✓ Feature supported

NB: Other manufacturer relays are available on request

Product characteristics

Options and accessories – EFI's

Earth fault and short-circuit indicators

Earth fault and short-circuit indicators are used for rapid location and isolation of faults on medium voltage, open loop ring main secondary distribution networks. Information can be forwarded via Relay an integral Gemini RTU or ModBus RS-485 communication for remote secondary distribution SCADA access.

We recommend the use of SupaRule and Horstmann EFIs with Aegis^{Plus}, with a list of compatible devices below:

	SIGMA F+E 3	SIGMA D / D+	ComPass A	ComPass B
<p>Manufacturer: Horstmann</p> <p>Models: SIGMA & ComPass</p> 				
Features				
Short-Circuit and Earth Fault Indication	✓	✓	✓	✓
Indication				
Directional indication	Non-directional	Directional	Non-directional	Directional
Phase selective	✓	✓	✓	✓
Monitoring				
Measurements	x	via software	✓	✓
Communication	x	USB	RS485/Modbus RTU	
General				
Remote-, Manual-, Automatic-Rest	✓	✓	✓	✓
Total flash time	>1000h	>1500h	>1000h	
Self powered	✓	✓	x	x
Auxiliary power supply	optional use 12-60V DC	optional use 24V AC, 24-60V DC	24-230V AC/DC	
Backup power supply	Long-life lithium cell, shelf life ≥ 20 years			
Relay contacts, permanent/momentary, NO/NC	3	4	4	4
Operating temperature	-30 to + 70 °C			
Housing	Plug-in			
IP protection / enclosure	IP 40		IP 50	
Dimensions (W x H x D)	96 x 48 x 96 mm	96 x 48 x 104 mm	96 x 48 x 96 mm	

Key ✓ Standard x Feature not available

	EARTH Zero	EARTH Zero	EARTH Zero 'Flag'	EARTH Zero 'Flag'	EARTH 4.0
<p>Manufacturer: Horstmann</p> <p>EFI Model: EARTH Zero</p> 					
Features					
Earth fault indicator	✓	✓	✓	✓	✓
Directional Indication	Non-directional				
Housing	Plug-in	Surface mount	Plug-in	Surface mount	
IP protection	IP40	IP65	IP40	IP65	
Enclosure	Polycarbonate (weather and sun-proof)				
Operating temperature	-30 to +70°C				
Power supply	Long-life lithium cell, shelf life ≥ 20 years				
Primary indication	Super bright RED LED		Super bright RED LED + RED flag		
Reset-Automatic by time	✓	✓	✓	✓	✓
Reset-By voltage restoration	(110 - 240 V AC)				
Total LED flash time	> 1.200 h				
Low battery indication	x	x	x	x	✓
Additional trip criteria	Line De-Energized				Vn = 0
Test/ Reset (Manual/ Automatic/ Remote)	o / o / -				o / o / o
Relay contacts	2 x changeover				2 x NO/NC
Remote flashing by external LED	• Relay contact provided, External LED as optional accessory				

Key • Standard * Other values possible on request.

	BLZ-50	BFZ-50	MFZ-50	MLZ-50	CFZ-50	CLZ-50
<p>Manufacturer: SupaRule</p> <p>EFI Model: Sensorform</p> 						
Features						
Power source	3.6V lithium ½ AA 850mAH battery		110-240V a.c.		CT on current carrying phase	
Voltage range	1-38kV					
Trip current	50A					
Primary indication	LED	Mech-flag (RED)		LED	Mech-flag (RED)	LED
Flashing duration	>1000 hrs	x	x	10 hrs	x	10 hrs
Minimum fault duration	2.5 cycles					
Manual reset	Push button					
Automatic timer reset	4 or 8 hrs selectable		10 secs after mains restore			
Manual trip test	Push button					
Operating temperature	-40°C to +80°C					
Operating humidity	0-100% RH					
Ingress protection	IP65					
Current sensor diameter:	CT100: 100mm	✓	✓	✓	✓	✓
	CT150: 150mm	o	o	o	o	o
	CT300: 300mm	o	o	o	o	o
Remote flashing LED indicator	o	o	o	o	o	o
Auxiliary relay, 1N/O latching	o	o	o	o	o	o

Key • Standard o Option

Other manufacturers' EFIs are also available on request, please contact your local Lucy Electric sales office for more information.

Product characteristics

Options and accessories – VPIS and VDS

Voltage Presence Indication System

The Voltage Presence Indication System (VPIS) receives a voltage signal through the voltage divider built into the cable bushings, enabling the operator to detect live voltage. It can also be fitted with neon lights and momentary latching push buttons to show voltage presence without needing external testing probes.

Three types of VPIS devices are available with Aegis^{Plus}:

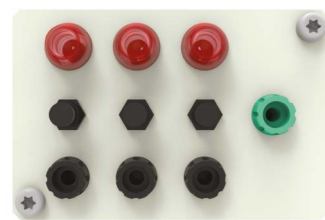

Neon indicators with push-to-test buttons and phase comparator sockets

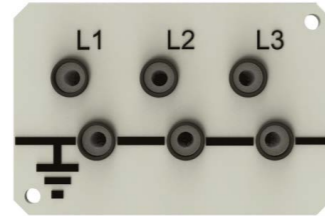

Sockets only for external indication and Pfisterer phase comparator device.









Georg Jordan VPIS with push to test and phase comparator sockets

Voltage Detection System

In addition to detecting the presence of voltage signals, the Voltage Detection System (VDS) can also detect the absence of voltage. This provides an additional layer of assurance and offers a reliable solution for monitoring voltage status within Aegis^{Plus}.

We recommend the use of Horstmann and Kries VDS devices, with a list of compatible systems below:

	WEGA 1.2 C	WEGA 2.2 C	WEGA 1.2 C vario	WEGA 3
Manufacturer: Horstmann				
VDS Model: WEGA				
				
				
Features				
Maintenance free	✓	✓	✓	✓
Connectivity	Always ready for connection to SIGMA D/D+, ComPass B			x
External power supply	x	24 – 230V (AC/DC)	x	x
Type of protection	IP54			
Enclosure	Fully moulded			
Operating temperature	-25 to +65°C			
Maintenance test	Automatic integrated maintenance test			
Display test function	By button			x
LRM interface	Full value LRM connection: L1/L2/L3/Ground (Conform to IEC 61243-5)			LRM Test point applicable for phase comparators
Rear	4 x 4.8mm tab 4-pin AMP plug	4 x 4.8mm tab 4-pin AMP plug 2-pin, 6-pin terminal block (Remote indication, Aux)	4 x 4.8mm tab 2 x 4-pin AMP connector Capacitor cube (pluggable)	4 x 4.8mm tab
Dimensions (W x H x D) For DIN cutout (according to DIN IEC 61554)	96 x 48 x 20 mm	96 x 48 x 52 mm	96 x 48 x 38 mm	96 x 48 x 20 mm

	Capdis S1+ (R4)	Capdis S2+ (R4)
Manufacturer: Kries		
VDS Model: Capdis		
Features		
Voltage detection	✓	✓
Voltage monitoring	x	✓
Interlock of earth switch	x	✓
Display	LCD	LCD + LED
Testing	Self and maintenance tests	
Relay output	x	2 changeover
Indication	Voltage present Maintenance test passed Overvoltage Asymmetric condition Broken lead	Voltage present Maintenance test passed Overvoltage Asymmetric condition Broken lead Aux. power missing
Auxiliary power	x	24 – 230V (AC/DC)
Interface to IKI	Y-Cable	
Accessories	Cable set	

✓ Standard x Feature not available

Other manufacturers' VDS devices are also available on request, please contact your local Lucy Electric sales office for more information.

Secondary injection

It is possible to check the operation of the protection and tripping of the circuit breaker by injecting a current to simulate the output of the CT under fault conditions. This can be carried out safely by earthing the CT secondary prior to opening the protection circuit.

Actuators (motors)

Aegis^{Plus} units are fitted on request with integrated 24V DC motors. When used in conjunction with the Gemini 3 RTU, these actuators enable remote operation of ring switches and circuit breakers.

In the event of mains AC supply failure, the motorised actuators can be powered directly from the Gemini 3 RTU 24V DC battery, ensuring continuation of operation reconfiguring the distribution network to isolate the fault and maintain supply.

NB: Motors on other voltages (other than 24 VDC) are available on request.

Shunt trip coils

Shunt trips are electro-magnetic coils that are used to trip circuit breakers through local push buttons, RTUs, or additional transformer protection devices. Shunt trips are available in the following voltages:

- DC voltage: 24V, 48V and 110V
- AC voltages: 110V, 240V
- Multiple voltage range: 24VDC – 240VAC

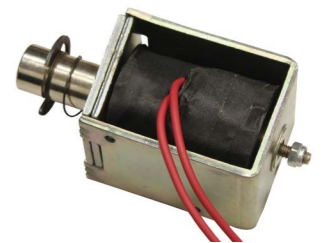

Product characteristics

Cable bushings and cable terminations

Cable bushings

Aegis^{Plus} uses the industry standard DIN 400 Type C bushings with in-line bolted connections and M16 threaded bolts in accordance with EN50181. The same bushings are used for both the Ring Switch and Circuit Breaker functions.

They are accessible by removing the interlocked cable compartment covers at the front of the unit.

The maximum supported cable sizes are:

- Up to 300mm² : 1 – core
- Up to 500mm² : 3 – core

Cable compartment

All of the cable clamps, glands and cable compartment sealing devices are available as retrofit options.



Single 3 core cable

3 single core cables

An extensive range of additional cable compartment clamps and sealing devices are available on request, please contact your local Lucy Electric sales office for more information.

Bolted separable connectors

We recommend the use of Tycoelectronics cable connectors, with a list of available solutions below:

Up to 12kV

TE Raychem Insulated T-adapter for SF6-insulated Switchgear, according to EN 50181 Type C

Model: RICS 3133 up to 12kV

Cross section (mm ²)	Ordering description T-Adapter	Termination for polymeric cables, incl. mechanical lugs
70 – 150	RICS - 3133	IXSU-F3131-ML-2-17
95 – 240	RICS - 3133	IXSU-F3131-ML-4-17
120 – 300	RICS - 3133	IXSU-F3131-ML-5-17



Cable terminations

The Aegis^{Plus} cable compartment is spacious and enables the easy installation of a range of cable termination types.

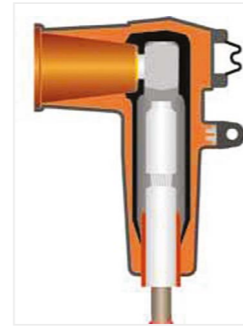

Up to 24kV

Profile 'C' bolted separable

High performance with rapid connection and disconnection

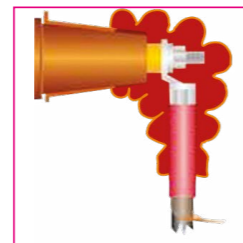

Up to 17.5kV

Insulating bushing boot

Tool free application with simple and easy installation



Up to 17.5kV

Heat-shrink insulating bushing boot

Excellent cable protection against environmental hazards and moisture

Up to 24kV

TE Raychem Screened, Separable Connection System

Model: RSTI-58 800 A up to 24kV (Single cable termination)

Technical data – with DIN compression lugs									
Screened separable connection system with DIN compression lugs									
Cross section	12kV Diameter core insulation		Reference number Conductor material		Cross section	24kV Diameter core insulation		Reference number Conductor material	
	mm ²	min. mm	max. mm	Al		Cu	mm ²	min. mm	max. mm
25	12.7-	23.4	RSTI-5810	RSTI-5830	25	12.7-	23.4	RSTI-5810	RSTI-5830
35	12.7-	23.4	RSTI-5811	RSTI-5831	35	12.7-	23.4	RSTI-5811	RSTI-5831
50	12.7-	23.4	RSTI-5812	RSTI-5832	50	12.7-	23.4	RSTI-5812	RSTI-5832
70	12.7-	23.4	RSTI-5813	RSTI-5833	70	12.7-	23.4	RSTI-5813	RSTI-5833
95	12.7-	23.4	RSTI-5814	RSTI-5834	95	21.2-	34.6	RSTI-5824	RSTI-5844
120	12.7-	23.4	RSTI-5815	RSTI-5835	120	21.2-	34.6	RSTI-5825	RSTI-5845
150	21.2-	34.6	RSTI-5826	RSTI-5846	150	21.2-	34.6	RSTI-5826	RSTI-5846
185	21.2-	34.6	RSTI-5827	RSTI-5847	185	21.2-	34.6	RSTI-5827	RSTI-5847
240	21.2-	34.6	RSTI-5828	RSTI-5848	240	21.2-	34.6	RSTI-5828	RSTI-5848
300	21.2-	34.6	RSTI-5829	RSTI-5849	300	21.2-	34.6	RSTI-5829	RSTI-5849

Technical data – mechanical lugs and shear bolts									
Cross section	12kV Diameter core insulation		Reference number Conductor material		Cross section	24kV Diameter core insulation		Reference number Conductor material	
	mm ²	min. mm	max. mm	Al or Cu		mm ²	min. mm	max. mm	Al or Cu
35-95	12.7-	23.4	RSTI-5851		35-70	12.7-	23.4	RSTI-5851	
95-120	12.7-	23.4	RSTI-5852		95-185	17.0-	30.1	RSTI-5853	
95-240	17.0-	30.1	RSTI-5853		95-240	21.2-	34.6	RSTI-5854	
150-240	21.2-	34.6	RSTI-5854		185-300	21.2-	34.6	RSTI-5855	
185-300	21.2-	34.6	RSTI-5855						
240-400	21.2-	34.6	RSTI-5856						



Product characteristics

Cable bushings and cable terminations

Up to 24kV

TE Raychem Screened, Separable Coupling System

Model: RSTI-CC-58 800 A up to 24kV (Double cable termination)

Technical data – with DIN compression lugs

Screened separable connection system with DIN compression lugs									
Cross section	12kV Diameter core insulation		Reference number Conductor material		Cross section	24kV Diameter core insulation		Reference number Conductor material	
	min. mm	max. mm	Al	Cu		mm ²	min. mm	max. mm	Al
25	12.7-	23.4	RSTICC-5810	RSTI-CC-5830	25	12.7-	23.4	RSTICC-5810	RSTI-CC-5830
35	12.7-	23.4	RSTI-CC-5811	RSTI-CC-5831	35	12.7-	23.4	RSTI-CC-5811	RSTI-CC-5831
50	12.7-	23.4	RSTI-CC-5812	RSTI-CC-5832	50	12.7-	23.4	RSTI-CC-5812	RSTI-CC-5832
70	12.7-	23.4	RSTI-CC-5813	RSTI-CC-5833	70	12.7-	23.4	RSTI-CC-5813	RSTI-CC-5833
95	12.7-	23.4	RSTI-CC-5814	RSTI-CC-5834	95	12.7-	23.4	RSTI-CC-5824	RSTI-CC-5844
120	12.7-	23.4	RSTI-CC-5815	RSTI-CC-5835	120	21.2-	34.6	RSTI-CC-5825	RSTI-CC-5845
150	21.2-	34.6	RSTI-CC-5826	RSTI-CC-5846	150	21.2-	34.6	RSTI-CC-5826	RSTI-CC-5846
185	21.2-	34.6	RSTI-CC-5827	RSTI-CC-5847	185	21.2-	34.6	RSTI-CC-5827	RSTI-CC-5847
240	21.2-	34.6	RSTI-CC-5828	RSTI-CC-5848	240	21.2-	34.6	RSTI-CC-5828	RSTI-CC-5848
300	21.2-	34.6	RSTI-CC-5829	RSTI-CC-5849	300	21.2-	34.6	RSTI-CC-5829	RSTI-CC-5849



Technical data – mechanical lugs and shear bolts

Cross section	12kV Diameter core insulation		Reference number Conductor material	Cross section	24kV Diameter core insulation		Reference number Conductor material
	min. mm	max. mm			mm ²	min. mm	
35-95	12.7-	23.4	RSTI-CC-5851	35-70	12.7-	23.4	RSTI-CC-5851
95-120	12.7-	23.4	RSTI-CC-5852	95-185	17.0-	30.1	RSTI-CC-5853
95-240	17.0-	30.1	RSTI-CC-5853	95-240	21.2-	34.6	RSTI-CC-5854
150-240	21.2-	34.6	RSTI-CC-5854	185-300	21.2-	34.6	RSTI-CC-5855
185-300	21.2-	34.6	RSTI-CC-5855				
240-400	21.2-	34.6	RSTI-CC-5856				

Insulating bushing boot connectors

Up to 17.5kV

TE Raychem Elastomeric Insulating Bushing Boot

Model: RCAB up to 17.5kV Single cable termination)

Technical data

	RCAB 4110	RCAB 4120
Maximum system voltage.	17.5kV	17.5kV
Basic impulse level	95kV	95kV
Collar size	No.1	none
Bushing diameter	31 - 45 mm	46 - 70 mm
Bushing types: to DIN, GENELEC, ANSI	–	400/630 A
Cable cross section	35 - 400 mm ²	35 - 400 mm ²



Heat shrink insulating bushing boot connectors

Up to 17.5kV

TE Raychem Heat Shrink Insulating Bushing Boot

Model: RSRB Series up to 17.5kV

Technical data – Right angle boots (long)

Catalogue Reference	Application Range (mm ²)
RSRB-4042	10 - 35
RSRB-4044	50 - 95
RSRB-4046	120 - 300

Technical data – Right angle boots (short)

RSRB-4062	10 - 35
RSRB-4064	50 - 95
RSRB-4066	120 - 300



Other manufacturers' cable terminations can be incorporated on request, please contact your local Lucy Electric sales office for more information.

Product characteristics

Cable bushings and cable terminations

Surge Arresters

Aegis^{Plus} is also fully compatible with surge arresters, which provide added protection against external and internal overvoltage occurrences. They ensure that voltage surges do not exceed the peak withstand voltage of Aegis^{Plus}; maximising protection.

Surge arrestors are easily installed via direct connection onto the DIN Type C bushings.

We recommend the use of Tycoelectronics surge arrestors, with a list of available solutions below:

Up to 24kV

TE Raychem Screened, Separable Surge Arrester

Model: RSTI-SA-05 up to 24kV

Technical data

Technical data for single and parallel connection

Rated Discharge Current I_N	5kA			
Operating duty High current Impulse 4/10 μ s	65kA			
Short Circuit Current I_S	16kA			
Long duration current impulse (1ms)	75A			
Residual Voltages (kV)				
Continuous operating voltage U_C	6	12	18	24
Rated Voltage U_R	7.5	15	22.5	30
Lightning Current Impulse 8/20 μ s				
2.5kA	19	38	57	76
5kA	20	40	60	80
10kA	21.7	43.5	65.2	87
Steep lightning current impulse 1/20 μ s				
5kA	21	42	63	84



Characteristics				
Voltage Class (kV)	6.0	12.0	18.0	24.0
Reference Number Single connection	RSTI-58A0605	RSTI-58SA1205	RSTI-58A1805	RSTI-58SA2405
Reference Number Parallel connection	RSTI-CC-58SA0605	RSTI-CC-58SA1205	RSTI-CC-58A1805	RSTI-CC-58SA2405
Dimension and Weight				
Length L* (mm)	285.0	285.0	400.0	400.0
Weight (kg/pc)				
(SBSA)	2.4	2.7	3.0	3.3
(-CC-58SA)	2.5	2.8	3.1	3.4

Other manufacturers' surge arresters can be incorporated on request, please contact your local Lucy Electric sales office for more information.

Internal arc protection

Internal arc classification (IAC)

Aegis^{Plus} is available in three internal arc protection formats:

- AF (Front protection)
- AFL (Front and lateral protection)
- AFLR (Front, lateral and rear protection)

These ratings are applicable to the SF6 insulated gas tank and the cable compartments. The units are configured on order, allowing for protection to be tailored to application requirements.

Methods of protection

AF and AFL protection is achieved by venting arc gases through the rear of the unit via a sacrificial metallic pressure relief plate.

AFLR protection is available in two formats; venting down through the cable trench, or by venting upwards through a dedicated chimney. These options maximise operational safety and provide a truly secure switchgear solution.



Metering unit

Aegis^{Plus} is compatible with a range of advanced Air Metering Units (AMUs), which offer full tariff metering capability. The new range is fully type tested to IEC 62271-200, and supports a wide range of conventional CTs and VTs.

Non-extensible and extensible options are available in both indoor and outdoor formats to suit a wide range of applications.

Characteristics

- 12, 17.5 and 24kV ratings
- Rated current 630A
- HV fuse protection for VT (optional)
- Isolation switch for testing / fuse change
- Isolation switch for disconnection of non-fused variant (optional)
- Panel door locking facility
- Double cable termination (optional)
- Anti-condensation space heater (optional)
- Wide range of CTs and VTs supported
- IP41 for indoor and IP54 for outdoor applications

NB: IP54 is available in (non-extensible) freestanding range only



Non-extensible AMU - Mt 1



Extensible AMU - Mt 2

Low voltage compartment

- Facility to lock and seal the terminal (marshalling) box (optional)
- Provision to disconnect and short circuit the CTs
- DIN96 size KWH meter, ammeter and voltmeters
- MCB / fuse protection for VT secondary side (optional)
- Trip lock out relay (for resetting relay in marshalling box before resetting circuit breaker (optional))
- Space heater with 110V Auxiliary supply (optional)
- 2.5mm diameter hole with glands for connecting remote KWH meter

Metering unit

Configurations available

Four metering functions are available:

Non-extensible range

- Mt: Cable In/Cable Out

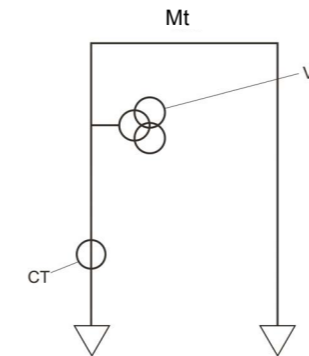

Metering Unit	Indoor	Outdoor
Mt	•	•

Extensible range

- M1: Busbar In/Busbar Out • M2: Cable In/Busbar Out • M3: Busbar In/Cable Out

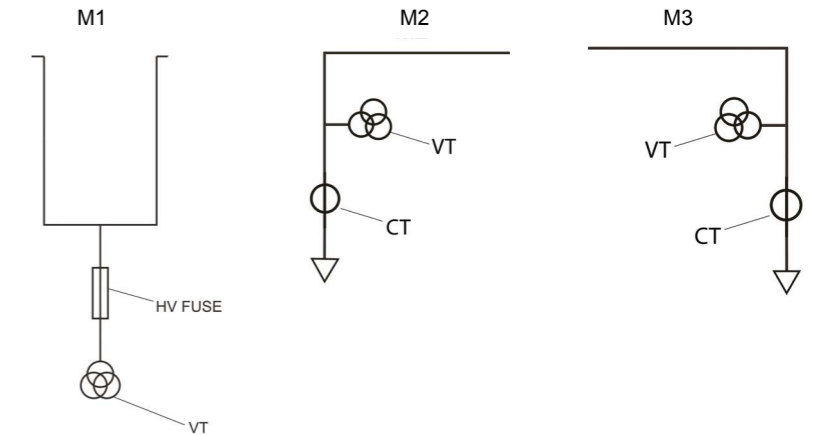

Metering units	LE	RE	Indoor	Outdoor
M1 (Busbar In/Busbar Out)	•	•	•	-
M2 (Cable In/Busbar Out)	-	•	•	-
M3 (Busbar In/Cable Out)	•	-	•	-

Key • Available - Not available

VT: All VTs are as per DIN42600 narrow type standard

No of VT	Type	VT Ratio	Burden	Class
1	3ph	11000/110V	10VA	0.5
			50VA	
			100VA	
1	3ph	11000/110V	50VA	0.2
			100VA	
			100VA	
1	3ph	11000/110V	50VA	1
			60VA	
			60VA	
1	3ph	22000/110V	50VA	0.5
			60VA	
			60VA	
3	1ph	11000/110V	50VA	0.5
			50VA	
			50VA	
3	1ph	22000/110V	50VA	0.5
			50VA	
			50VA	
3	1ph	11000/110V	30VA	0.2
			50VA	
			50VA	
3	1ph	11000/110	50VA	1
			50VA	
			50VA	

CT ratios

No of CT	CT Ratio	Burden	Class
2/3	50-25/1A	10VA	0.2/0.5
	50/25/5A	10VA	0.5
	100-50/1A	10VA	0.2/0.5
	100/50/5A	10VA	0.5
	100/50/5A	15VA	0.5
	200-100/1A	10VA	0.2/0.5
	200-100/1A	15VA	0.2/0.5
	200/100/5A	5VA	0.5
	200/100/5A	15VA	0.5
	300/150/5A	5VA	0.5
	300/150/5A	15VA	1
	400/200/5A	15VA	0.2/0.5
400/200/5A	20VA	0.5	

NB: CTs and VTs shown above are part of our standard range, a wider range is available on request.

Smart-grid ready

Our Gemini automation portfolio enables customers to build intelligent, future ready smart grid networks. Engineered for high performance across both ground and pole mounted MV installations, our solutions deliver the reliability, efficiency, and flexibility needed to drive smarter, more resilient distribution systems.

The Gemini platform provides the user with a consistent approach and interface experience with a common look and feel, communication and configuration environment.

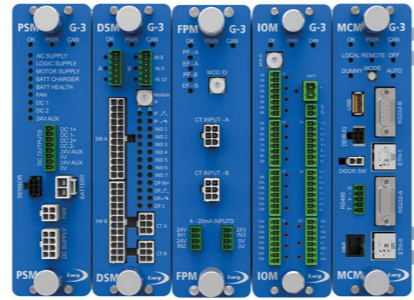

Gemini 3 RTU integration

Aegis^{Plus} can be configured with the next-generation Gemini 3 RTU. This highly flexible Remote Terminal Unit (RTU) incorporates a range of features allowing customers to build in flexibility and scalability to their network automation needs.

The Gemini 3 has a modular design such that it can be configured from a simple monitoring only device to a fully functional automated switch controller. It has the ability to transition from a basic to an advanced RTU by plugging in additional modules.

The Gemini 3 modules available are:

Master Control Module (MCM) – This contains the main processor and supervises all modules. The MCM handles the protocol communications.

Dual Switch Module (DSM) – This provides the inputs and outputs to perform secure interlocked control of two MV ring switches

Power Supply Module (PSM) – This module works with the switch control modules to provide secure switching operations. The PSM generates regulated power to all other modules and external communication equipment. The PSM also provides the intelligent battery charging function to maintain a secure supply.

Input Output Module (IOM) – This is a general purpose module that covers digital and analogue inputs and relay outputs.

Fault Passage Module (FPM) – This is a dual fault passage indicator module which detects and alarms for Overcurrent and Earth Faults.

Human to Machine Interface (HMI) – This is an optional module that allows local control and monitoring without the need for a Computer. It allows local controls to be issued by an authorised Engineer (security enabled) or just provide data to be viewed locally.

Characteristics

- Safe control of multiple switches (patent number GB2534376)
- Battery management functions

- Automation schemes
 - Automatic sectionalising
 - Automatic change-over
 - Parasitic load tripping for meshed LV networks
- Flexible inputs and outputs
- Fault detection (Earth and Phase)
- LED status indicators
- Real time clock (SCADA synchronised)
- Flexible connectivity
- Dual isolated Ethernet and RS232 ports
 - Isolated RS485 port
- Supervisory selection and indication
- Event memory – 7000 events in non-volatile memory
- Communication protocol
 - DNP 3.0 TCP/IP or Serial
 - IEC 60870-5-101/103/104
 - Modbus TCP or RTU
- Rugged design for harsh environments
- Maintenance free

Advanced cybersecurity

The Gemini RTU uses a number of techniques to eliminate security vulnerabilities including:

- Role Based Access Control (RBAC)
- Centralized Authentication using LDAP
- Secure Firmware Updates
- Ethernet Port Management
- SNMP
- Non-erasable cyber event recorder (Syslog for SEM)
- Enhanced Authentication & Encryption
- Secure IEC 60870-5-104 connection based on IEC 62351-3 TLS

Integrated design

Gemini 3 is an optional feature for Aegis^{Plus}, integrated neatly in the upper LV compartment of the unit (factory fitted). This eliminates the need for an additional exterior control box and associated cabling on site.

Smart-grid ready

Gemini 3 RTU integration

Key features of Gemini 3

- Embedded auto change over and auto sectionalising functions
- Real time network condition monitoring of voltage, current, power, power factor and frequency
- Flexible communication through radio, RS232, RS485, packet data network, GSM, GPRS, PSTN, ethernet TCP/IP and optical fibre.
- Advanced battery pack to operate under mains AC input failure
- Fully tested to ENATS (Energy Network Association Technical Standards), EMC and environmental standards

Benefits of Automation

- Reduced time in diagnosing system anomalies as well as locating and isolating faulty sections of the network
- Faster response time and quick network reconfiguration
- Optimisation of asset management through the implementation of customised automation schemes
- Reduced operational cost associated with routine network switching
- Increased operator safety

Automatic transfer scheme

Aegis^{Plus} coupled with Gemini 3 offers full Automatic Transfer Scheme support. This provides the rapid and reliable transfer of the system from one power source to another, in the event of normal source failure. The result is an added layer of reliability in the power supply.

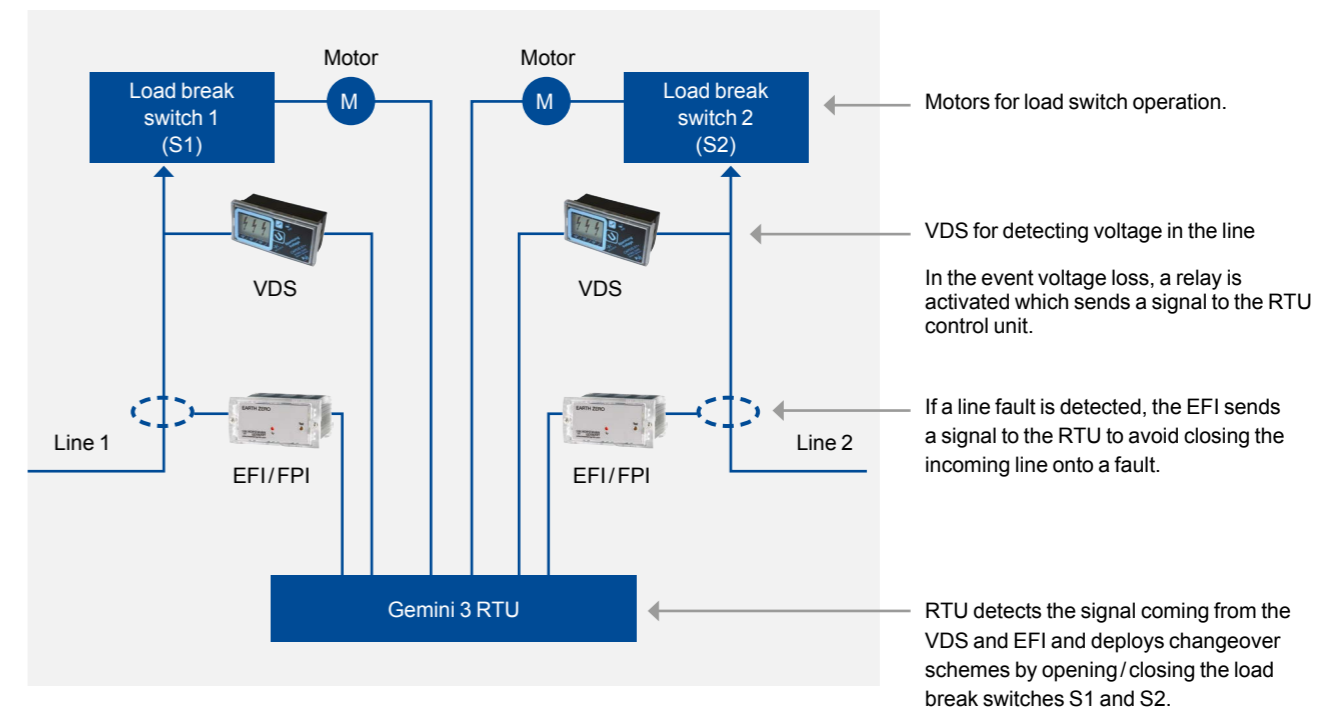

Gemini 4 RTU integration

The Gemini 4 RTU forms part of the Gemini platform, providing advanced monitoring and control capabilities for medium voltage switchgear.

The Gemini 4 RTU is DIN rail mounted, providing the optimum suitability and footprint for controlling overhead and ground mount switchgear. The Gemini 4 RTU comprises up to seven factory fitted sub-assemblies which can control up to seven switches. This can be extended to 28 switch control with the addition of Gemini 4 Expansion Units.



Key features

- Dedicated "motor power enable" relay output providing safe and secure operation of switchgear
- Secure control operations for multiple switches using dedicated signals
- User configurable inputs and outputs, optional HMI
- Analogue inputs via communication interface
- I/O have associated LED indicators
- Digital inputs support dry contacts—no external wetting voltage required
- Flexible communication options
 - IEC60870-5-101/103/104
 - DNP 3.0
 - Modbus
 - Multiple masters
- Web browser interface for configuration
- Programmable logic
- Automation schemes support (eg. Automatic sectionalising, Automatic change-over)
- Enhanced cyber security features for use in Critical National Infrastructure
- Secure firmware and configurable SMS reset function
- Simple DIN rail mounting, saving time and simplifying maintenance
- Optimised form factor providing efficient assembly into control cabinets and switchgear panels
- Easy to configure, customisable product adapting to different solutions
- Pluggable terminal blocks improving installation times

Gemini Analogue Measurement Module (AMM)

The Gemini Analogue Measurement Module (AMM) is part of the Gemini platform providing advanced 3 phase measurement of power system currents, voltages, power, energy, sequence components, power quality; and directional fault passage indication. AMM module seamlessly integrates with the Gemini RTUs providing enhanced grid situational awareness, covering utility & industrial applications effectively.



Key features

- Accurate current & voltage measurement
- Real time Power, energy & Power factor Data
- Advanced Power Quality monitoring (incl. Harmonics)
- Directional Fault Passage Indication
- Ethernet & CAN Bus communication
- Compatible with standard CTs, VTs and instrument transformers compliant to IEC 61869 10/11
- Supports Multi Feeder Monitoring (up to 3 feeders)
- High performance signal processing
- Compact, robust design with no internal Batteries
- Hardened for Substation environments
- Suitable for both overhead and ground Mounted Installations

Gemini DC Analogue Input Module

The Gemini DC Analogue Input Module is part of the Gemini platform providing DC analogue measurement inputs for the Gemini RTUs. This product can be applied for covering applications like Transformer monitoring (temperature, tap position indication), underground cable oil/gas pressure monitoring and humidity measurement.



Key features

- DC Analogue signal inputs (up to 4)
 - 0V to +5V / -5V to +5V
 - 0V to +10V / -10V to +10V
 - 4mA to 20mA / -20mA to +20mA
 - 0mA to +20mA
- Temperature inputs (up to 2)
 - PT100 (4 wire)
- Accurate measurement
- Sensor Fault detection & reporting
- Standard Modbus interface for seamless integration

Technical data

Aegis^{Plus} ring main unit

Rated voltage	kV	12	17.5	24
---------------	----	----	------	----

General

Rated frequency	Hz	50	50 / 60	50
Switchgear Classification		PM Class (Metallic partitioning)		
Loss of Service Continuity		LSC2		

Rated lightning impulse withstand voltage

Directly earthed	kV	75	95	125
Across disconnector	kV	85	110	145

Rated power frequency withstand voltage

Directly earthed	kV	28	38	50
Across disconnector	kV	32	45	60

Protection

Indoor	IP	IP41		
Outdoor (Non-extensible)	IP	IP54		
Tank with HV parts	IP	IP67		
Mechanical impact protection	IK	IK07 (indoor) IK10 (outdoor)		

Internal arc rating

AF	KA 1 sec	20	20	20
AFL	KA 1 sec	20	20	20
AFLR	KA 1 sec	20	20	20

SF6 gas

Annual leakage rate		≤ 0.1%		
Filled pressure (at 20°C)	Bar (G)	0.4		
Minimum operating pressure	Bar (G)	0.1		

Installation conditions

Maximum altitude (without derating)*	Meters ASL	1000		
Relative humidity (max) – over period of 24hrs (IEC 62271-1, sub-clause 2.1)		95%		

Busbars

Rated normal current	A	630		
Rated short time withstand current	kA	21/25		
Rated duration of short circuit	s	3/1		
Rated peak withstand current	kA	52.5/62.5		

Load Break Switch : L function

Rated normal current	A	630		
Rated active load breaking current	A	630		
Rated cable-charging breaking current (I _{cc})	A	10/160	10	160
Rated line-charging breaking current (I _{lc})	A	1.5	1.5	1.5
Rated earth fault breaking current (I _{eff1})	A	48	48	150
Rated cable and line-charging breaking current under earth fault condition (I _{eff2})	A	28	28	87

Main electrical circuit

Rated short time withstand current	kA	21	21	21
Rated duration of short circuit	s	3	3/1	3
Rated peak withstand current	kA	52.5	52.5/54.6	52.5

Rated voltage	kV	12	17.5	24
---------------	----	----	------	----

Earthing circuit

Rated short time withstand current	kA	21	21	21
Rated duration of short circuit	s	3	3 @ 50Hz 1 @ 60Hz	3
Rated peak withstand current	kA	52.5	52.5/54.6	52.5

Mechanical endurance class

Load break switch		M2		
Earth switch		M0		

Electrical endurance class short circuit making

Load break switch		E3		
Earth switch		E2		

Operating mechanism

Local: Close – Open		Hand Lever		
Remote: Close – Open		Motor		

Fused Switch : F function

*17.5kV is not available

Rated normal busbar current	A	630		
Rated normal fuse current	A	200		

Main electrical circuit

Rated short time withstand current	kA	21	-	21
Rated duration of short circuit	s	3	-	3
Rated peak withstand current	kA	52.5	-	52.5

Upstream earthing circuit

Rated short time withstand current	kA	21	-	21
Rated duration of short circuit	s	3	-	3
Rated peak withstand current	kA	52.5	-	52.5

Downstream earthing circuit

Rated short time withstand current	kA	2.5	-	2.5
Rated duration of short circuit	s	1	-	1

Mechanical endurance class

Fused switch		M1		
Upstream earth switch		M0		
Downstream earth switch		M0		

Electrical endurance class short circuit making

Fused switch		E2		
Upstream earth switch		E2		
Downstream earth switch		E2		

Operating mechanism

Local		Hand lever		
Remote		Motor		

* For higher altitude applications please contact your local Lucy Electric sales office

Technical data

Aegis^{Plus} ring main unit & air metering unit

Rated voltage	kV	12	17.5	24
---------------	----	----	------	----

Circuit Breaker : V function (Non-auto reclose)

Rated normal current	A	630		
Rated active load breaking current	A	630		
Rated short circuit breaking current	kA	21	21	21
Rated short circuit making current	kA	52.5	52.5/54.6	52.5
Rated cable charging breaking current	A	25	31.5	31.5

Main electrical circuit

Rated short time withstand current	kA	21	21	21
Rated duration of short circuit	s	3	3 @ 50Hz 1 @ 60Hz	3
Rated peak withstand current	kA	52.5	52.5/54.6	52.5

Earthing circuit

Rated short time withstand current	kA	21	21	21
Rated duration of short circuit	s	3	3 @ 50Hz 1 @ 60Hz	3
Rated peak withstand current	kA	52.5	52.5/54.6	52.5

Mechanical endurance class

Circuit breaker		M1		
Earth switch		M0		

Electrical endurance class

Circuit breaker		E2		
Earth switch		E2		

Operating mechanism

Operating sequence for mechanism		O-3min-CO-3min-CO		
Local: Close – Open		Hand Lever - Pushbutton		
Remote: Close – Open		Motor – Coil		

Circuit Breaker : C function (Auto reclose)

Rated normal current	A	630		
Rated active load breaking current	A	630		
Rated short circuit breaking current	kA	21	-	21
Rated short circuit making current	kA	52.5	-	52.5
Rated cable charging breaking current	A	25	-	31.5

Main electrical circuit

Rated short time withstand current	kA	21	-	21
Rated duration of short circuit	s	3	-	3
Rated peak withstand current	kA	52.5	-	52.5

Earthing circuit

Rated short time withstand current	kA	21	-	21
Rated duration of short circuit	s	3	-	3
Rated peak withstand current	kA	52.5	-	52.5

Mechanical endurance class

Circuit breaker		M2		
Earth switch		M0		

Electrical endurance class

Circuit breaker		E2		
Earth switch		E2		

Rated voltage	kV	12	17.5	24
---------------	----	----	------	----

Operating mechanism

Operating sequence for mechanism		O-0.3s-CO-3min-CO		
Local: Close – Open		Pushbutton		
Remote: Close – Open		Motor – Coil		

Circuit Breaker: T function

Rated normal current	A	200/250 *		
Rated active load breaking current	A	200/250 *		
Rated short circuit breaking current	kA	21	21	21
Rated short circuit making current	kA	52.5	52.5/54.6	52.5
Rated cable charging breaking current	A	25	31.5	31.5

Main electrical circuit

Rated short time withstand current	kA	21	21	21
Rated duration of short circuit	s	3	3	3
Rated peak withstand current	kA	52.5	52.5/54.6	52.5

Earthing circuit

Rated short time withstand current	kA	21	21	21
Rated duration of short circuit	s	3	3 @ 50Hz 1 @ 60Hz	3
Rated peak withstand current	kA	52.5	52.5/54.6	52.5

Mechanical endurance class

Circuit breaker		M1		
Earth switch		M0		

Electrical endurance class

Circuit breaker		E2		
Earth switch		E2		

Operating mechanism

Operating sequence for mechanism		O-3min-CO-3min-CO		
Local: Close – Open		Hand lever – Pushbutton		
Remote: Close – Open		Motor – Coil		

Direct Cable Connection (R)

Rated normal current	A	630		
Rated short time withstand current	kA	21	-	21
Rated duration of short circuit	s	3	-	3
Rated peak withstand current	kA	52.5	-	52.5

* 200 A DIN 200 Type A, 250 A DIN 400 Type C cable bushings

Technical data

Aegis^{Plus} ring main unit & air metering unit

Rated voltage	kV	12	24
---------------	----	----	----

Busbar Sectionaliser SL (Switch) *(1)

Rated normal current	A	630		
Rated active load breaking current	A	630		
Rated cable-charging breaking current (I _{cc})	A	10/160	-	160
Rated line-charging breaking current (I _{lc})	A	1.5	-	1.5
Rated earth fault breaking current (I _{ef1})	A	48	-	150
Rated cable and line-charging breaking current under earth fault condition (I _{ef2})	A	28	-	87

Main electrical circuit				
Rated short time withstand current	kA	21	-	21
Rated duration of short circuit	s	3	-	3
Rated peak withstand current	kA	52.5	-	52.5

Earthing circuit				
Rated short time withstand current	kA	21	-	21
Rated duration of short circuit	s	3	-	3
Rated peak withstand current	kA	52.5	-	52.5

Mechanical endurance class				
Load break switch		M2		
Earth switch		M0		

Electrical endurance class short circuit				
Load break switch		E3		
Earth switch		E2		

Operating mechanism				
Local: Close – Open		Hand Lever		
Remote: Close – Open		Motor		

Busbar Earthing (Be) *(1)

Rated normal current	A	630		
Rated active load breaking current	A	630		

Earthing circuit				
Rated short time withstand current	kA	21	-	21
Rated duration of short circuit	s	3	-	3
Rated peak withstand current	kA	52.5	-	52.5

Mechanical endurance class				
Earth switch		M0		

Electrical endurance class				
Earth switch		E2		

Operating mechanism				
Local: Close – Open		Hand lever		
Remote: Close – Open		Motor		

Rated voltage	kV	12	24
---------------	----	----	----

Busbar Sectionaliser SV (Circuit Breaker) *(1)

Rated normal current	A	630		
Rated active load breaking current	A	630		
Rated short circuit breaking current	kA	21	-	21
Rated short circuit making current	kA	52.5	-	52.5
Rated cable charging breaking current	A	25	-	31.5

Main electrical circuit				
Rated short time withstand current	kA	21	-	21
Rated duration of short circuit	s	3	-	3
Rated peak withstand current	kA	52.5	-	52.5

Earthing circuit				
Rated short time withstand current	kA	21	-	21
Rated duration of short circuit	s	3	-	3
Rated peak withstand current	kA	52.5	-	52.5

Mechanical endurance class				
Circuit breaker		M1		
Earth switch		M0		

Electrical endurance class				
Circuit breaker		E2		
Earth switch		E2		

Operating mechanism				
Operating sequence for mechanism		O-3min-CO-3min-CO		
Local: Close – Open		Hand Lever – Pushbutton		
Remote: Close – Open		Motor – Coil		

Air Metering Unit

Rated voltage				
Frequency	Hz	50	50/60	50
Rated Current	A	630	630	630
Impulse withstand voltage (between poles and earth)	kV	75	95	125
Power frequency with stand voltage (1 min between poles and earth)	kV	28	38	50
Peak with stand current	kA	50	50	50
Short circuit making current	kA	50	50	50
Short time withstand current	kA 1s/3s	20/21	20/21	20
Busbar size cross section	mm ²	160	160	160
Internal Arc				
AF	kA 1s	20	21	20

*(1) Function is not available in 17.5kV 60Hz range

* 200 A DIN 200 Type A, 250 A DIN 400 Type C cable bushings

Dimensions

Aegis^{Plus} ring main unit

Non extensible and extensible RMU

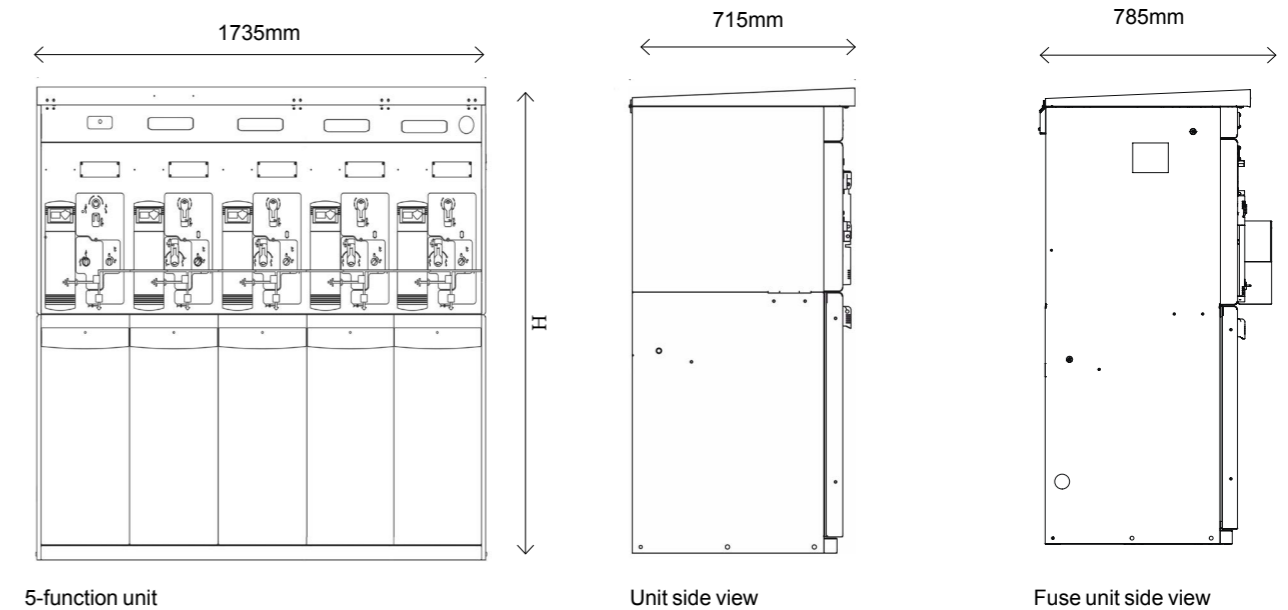
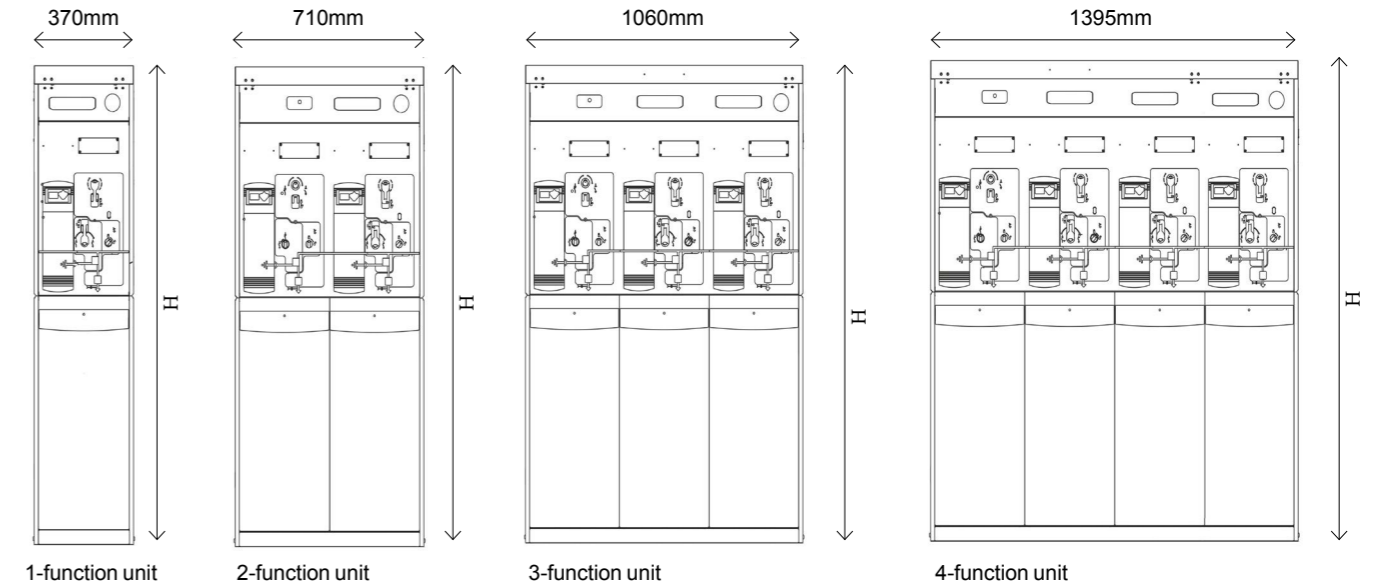

Cable Termination Height (mm)	H = Overall unit height (mm) ^{1,2}	
	Relay/TLF fitted	G3 RTU fitted
450	1280	1430
600	1430 *	1580
750	1580	1730

The distance between two coupled Aegis^{Plus} units is 60mm

¹ Side extensible units have 100mm additional height

² Outdoor (NE) units have 10mm additional height

*Top extensible units have 300mm additional height

Dimensions

Air metering unit

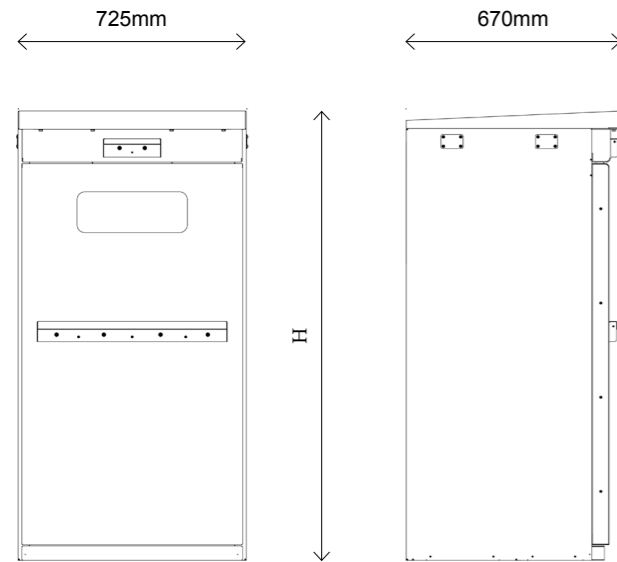

Non-extensible air metering unit

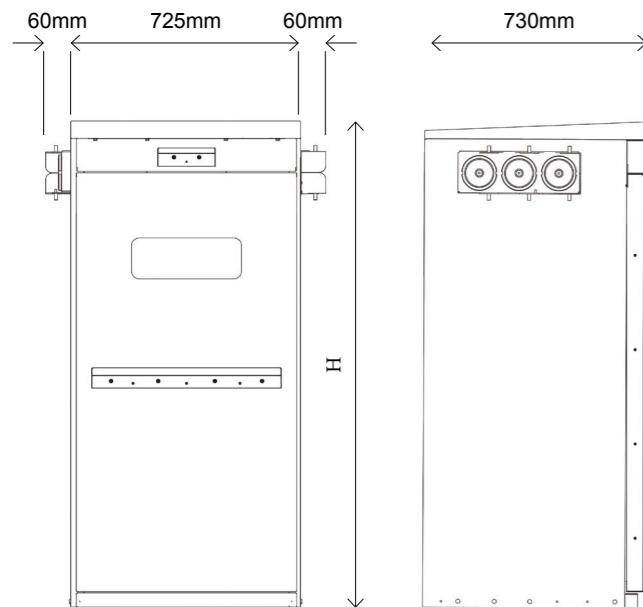

Extensible air metering unit

Cable termination height (mm)	Height (mm)
450	1280
600	1430
750	1580

Cable termination height (mm)	Height (mm)
450	1380
600	1530
750	1680

Aegis^{Plus} order form

To use this form, please fill in the appropriate sections and return the completed form to your nearest Lucy Electric sales office

Name: _____
 Address: _____

Company: _____
 Tel no: _____
 Email: _____
 Order number: _____

Order quantity / number of units (please fill separate form for each type)

Extensibility (choose any one) Non extensible
 Top extensible
 Side extensible

left hand right hand both sides
 left hand right hand both sides

IP rating: Installation conditions (choose any one)
 IP54 Outdoor (available for non extensible and top extensible ranges)
 IP41 Indoor (available for extensible and non extensible range)

Features common to all functions

Voltage rating (choose any one) 12kV 17.5kV 24kV
 Low gas pressure alarm 1N/O (one per tank)

Functions required:
 Starting from the left, write L, T, V or C in each box depending on the number of functions needed.

Type of function	12/17.5/24kV
L - LBS	630A
T - VCB (Non-auto reclose)	250A
V - VCB (Non-auto reclose)	630A
F - Fuse	200 A
C - VCB (auto reclose)	630A
AMU - Metering	

First (e.g. 1 function) Second (e.g. 2 function) Third (e.g. 3 function) Fourth (e.g. 4 function) Fifth (e.g. 5 function)

Motor wiring only (required for future motorisation)
 Motor with wiring (tick for each selected function, if needed)
 Cable Earth & Test facility (E&T) (tick for each selected function, if needed)
 Cable bushings termination height (choose any one) 450mm 600mm 750mm
 Cable compartment
 Cable clamp material (choose any one) Metal Plastic
 Cable entry type (choose any one) 3 single core cable Single 3 core cable

<input type="checkbox"/>	<input type="checkbox"/>	<input type="checkbox"/>	<input type="checkbox"/>	<input type="checkbox"/>
<input type="checkbox"/>	<input type="checkbox"/>	<input type="checkbox"/>	<input type="checkbox"/>	<input type="checkbox"/>
<input type="checkbox"/>	<input type="checkbox"/>	<input type="checkbox"/>	<input type="checkbox"/>	<input type="checkbox"/>
<input type="checkbox"/>	<input type="checkbox"/>	<input type="checkbox"/>	<input type="checkbox"/>	<input type="checkbox"/>
<input type="checkbox"/>	<input type="checkbox"/>	<input type="checkbox"/>	<input type="checkbox"/>	<input type="checkbox"/>
<input type="checkbox"/>	<input type="checkbox"/>	<input type="checkbox"/>	<input type="checkbox"/>	<input type="checkbox"/>
<input type="checkbox"/>	<input type="checkbox"/>	<input type="checkbox"/>	<input type="checkbox"/>	<input type="checkbox"/>
<input type="checkbox"/>	<input type="checkbox"/>	<input type="checkbox"/>	<input type="checkbox"/>	<input type="checkbox"/>

Internal arc
 Gas enclosure
 Cable box
 Internal arc classification*

* Not available on 450mm cable compartments AF AFL
 Bottom venting into cable trench - AFLR

Auxiliary switches (choose any one) 1N/O, 1N/C 2N/O, 2N/C

Our offices:

Lucy Electric:
Howland Road
Thame
Oxfordshire
OX9 3UJ. United Kingdom
t: +44 (0) 1844 267267
f: +44 (0) 1844 267223

Lucy Electric Digital
Solutions Ltd:
Howland Road
Thame
Oxfordshire
OX9 3UJ. United Kingdom
t: +44 (0) 1268 850000

Lucy Electric Digital
Solutions Ltd:
8 Argent Court
Sylvan Way
Southfields Business Park
Basildon
Essex SS15 6TH
t: +44 (0) 1268 968922

Lucy Electric Digital
Solutions Ltd:
607 Delta
Welton Road
Swindon
SN5 7XF
t: +44 (0) 1268 850000

Lucy Middle East FZE:
N400 Road, JAFZA North,
Plot MO 0161, P.O. Box 17335,
Jebel Ali, Dubai, UAE
t: 04-8129999
f: 04-8129900

Lucy Switchgear (FZE):
PO Box 17709, Plot No:
MO0409, Jebel Ali Free
Zone, Dubai
United Arab Emirates
t: +971 @ 8080333 ext. 6261
f: +971 @ 8080444

Lucy Electric India Private Ltd:
Zone South Sales Office 79/2,
City Centre, 4th Floor
Hennur-Bellary Outer Ring
Road, Opp. Hebbal BMTC
Bus Depot, Bangalore -
560024 Karnataka, India

Lucy Electric India Private Ltd:
F-10, MIDC
Ambad
Nasik 422010
India
t: +91 253 2381603

Lucy Electric Manufacturing
& Technologies Private Ltd:
R.S. No: 26-30, Village
Noorpura Post : Baska
besides Polycab, Halol
Baroda Toll Road, Taluka
Halol, District: Panchmahal,
GUJARAT 389350. India
tel/fax: +91 2676 304901/2

Lucy Electric India Private Ltd:
2B - 46 & 47, 2nd Floor,
Phoenix Paragon Plaza
LBS Marg, Kuria West
Mumbai 400070
Maharashtra, India
t: +91 22 62366616

Lucy Electric India Private Ltd:
Zone North Sales Office
4B/06, 4th Floor, Crown Plaza
27/5 Mathura Road, Sector
15A Faridabad - 121007
Near Neelam Chowk Ajrona
Metro Station, Haryana
India

Lucy Electric (Thailand) Ltd:
388 Exchange Tower, 37th
Floor Unit 3702, Sukhumvit
Road, Klongtoey Sub district,
Klongtoey District, Bangkok,
10110, Thailand
t: +66(02) 663 4290
Email: salesthailand@
lucyelectric.com

Lucy Electric (Thailand) Ltd:
500/64 M.3
Hemaraj Eastern Seaboard
Industrial Estate, (Free Zone)
Tasit, Pluakdeang Rayong
21140
t: + 66 (0)33 684 333
Ext. 6000
Email: salesthailand@
lucyelectric.com

Lucy Asia Pacific Sdn Bhd
(LAP):
L11-07 & L11-08, Level 11
PJX HM Shah Tower
No 16A, Persiaran Barat
46050 Petaling Jaya Selangor
t: +603 74910700
Email: salesMalaysia@
lucygroup.com

Lucy Switchgear Arabia
Co. Ltd:
Riyadh Office, Short Address:
RUQB6171, Building No:6171
Said Bin Zaid Street
Secondary No: 2836
Qurtubah Dist. Postal code:
13245 First Floor Office No: 21
City: Riyadh, Kingdom of
Saudi Arabia

Lucy Switchgear Arabia
Co. Ltd:
Dhahran Factory, Short
Address: ELDA3362
Building No:3362,
Al Widad Street
Secondary No: 7357 Adh
Dhahran Industrial Dist.
Postal code: 34521
City: Dhahran, Kingdom
of Saudi Arabia

Lucy Switchgear Arabia
Co. Ltd:
Jeddah Office,
Short Address: JERA4039
Building No:4039 Qasim
Zinah Street
Secondary No:8781
Ar Rawdah Dist.
Postal code: 23434
City: Jeddah, Kingdom
of Saudi Arabia

Lucy Electric South Africa
(Pty) Ltd:
3 Sacks Circle,
Bellville South
Cape Town 7530,
South Africa
t: +27(0)11 0257490

Lucy Electric East Africa:
13th Floor Landmark Plaza
Argwings Khodhek Road
PO Box 00606
Nairobi
Kenya
t: +254 (20) 20 3673 927

Lucy Electric South Africa
(Pty) Ltd:
Unit 12 & 13, Block C,
Honeydew Business Park,
1503 Citrus Street, Laser Park
Honeydew 2170
South Africa
t: +27(0)11 0257490

Lucy Equipamentos
Elétricos Ltda:
Av. das Araucárias 2558
Thomaz Coelho
CEP 83707-067
Araucária
Paraná State, Brazil
t: +55 (41) 2106 2801

Lucy Electric Australasia
Pty Ltd:
Jubilee Place,
470 Saint Pauls Terrace
Fortitude Valley, 4006 QLD
Australia
t: +61 467 237 879
Email: salesaustralia@
lucyelectric.com

Lucy Electric EV
Infrastructure Ltd:
Station Road
Sowerby Bridge
West Yorkshire, HX6 3AF
t: +44 (0)1422 553 000

Lucy Electric Energy
Services Ltd:
Howland Road
Thame
Oxfordshire
OX9 3UJ. United Kingdom
t: +44 (0)1844 267 256

Disclaimer

Lucy Electric has a policy of continuous research and development and accordingly reserves the right to change the design and specification of its products without prior notice.